

CATALOGO DE SUAJES PARA IMPRESION FLEXO

(Corte estandar)

INDICE

GUIA PARA LA SELECCION DE SUAJES.....	Pag. 01
RECTANGULOS VERTICALES	Pag. 02 a la 06
CUADRADOS.....	Pag. 07
RECTANGULOS HORIZONTALES.....	Pag. 08 a la 36
CIRCULOS	Pag. 37
OVALOS	Pag. 38
FIGURAS ESPECIALES	Pag. 39 a la 71
CORTE DE SEGURIDAD	Pag. 72

GUIA PARA LA SELECCION DE SUAJES

FORMA DEL SUAJE

MEDIDA: A= Medida en sentido longitudinal al rollo.
B= Medida en sentido transversal al rollo.

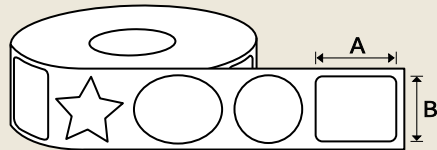

Fig. 1

108/54/2
A= 40 mm
B= 60 mm
MAQUINAS= 7,8

Fig. 2

MAQUINA: Indica la(s) máquina(s) en la(s) que se puede utilizar el suaje.
Revise la Fig. 3 para asegurarse que la combinación "SUAJE - MAQUINA" que selecciono se adecua a sus necesidades.

NUMERO DE SUAJE: Haga referencia a este número cuando seleccione el suaje.

CAPACIDAD DEL EQUIPO DE IMPRESION

MAQUINA	NUMERO DE TINTAS MAXIMO	ACABADOS DISPONIBLES	TIPO DE IMPRESION	TIRAJE
3	6 ó 5 + BARNIZ	LAMINACION BARNIZ U.V. BARNIZ STD.	TINTAS DIRECTAS Y SELECCION DE COLOR	BAJO ó MEDIO
4	6 ó 5 + BARNIZ	LAMINACION BARNIZ U.V. BARNIZ STD.	TINTAS DIRECTAS Y SELECCION DE COLOR	BAJO ó MEDIO
7	7 ó 6 + BARNIZ	LAMINACION BARNIZ U.V. BARNIZ STD.	TINTAS DIRECTAS Y SELECCION DE COLOR	MEDIO ó ALTO
8	6 ó 5 + BARNIZ	LAMINACION BARNIZ U.V. BARNIZ STD.	TINTAS DIRECTAS Y SELECCION DE COLOR	MEDIO ó ALTO
10	8 ó 7 + BARNIZ	LAMINACION BARNIZ U.V. BARNIZ STD.	TINTAS DIRECTAS, SELECCION DE COLOR Y ESTAMPADO	MEDIO ó ALTO

Fig. 3

PARA VER EL CATALOGO COMPLETO VEA LAS PAGINAS 02 A LA 72

NOTA: Los suajes marcados con "*" son de uso exclusivo y requieren autorización para su uso.



RECTANGULOS VERTICALES

732/62/1
A= 74 mm
B= 150 mm
MAQUINAS= 3,4

732/79/2
A= 62.7 mm
B= 147 mm
MAQUINAS= 3,4

732/79/4
A= 62.7 mm
B= 135 mm
MAQUINAS= 3,4

108/64/2
A= 47.6 mm
B= 101.6 mm
MAQUINAS= 7,8,10

632/79/8
A= 29.65 mm
B= 63 mm
MAQUINAS= 3,4

108/68/4
A= 40 mm
B= 127 mm
MAQUINAS= 7,8,10

632/68/8
A= 25 mm
B= 70 mm
MAQUINAS= 3,4

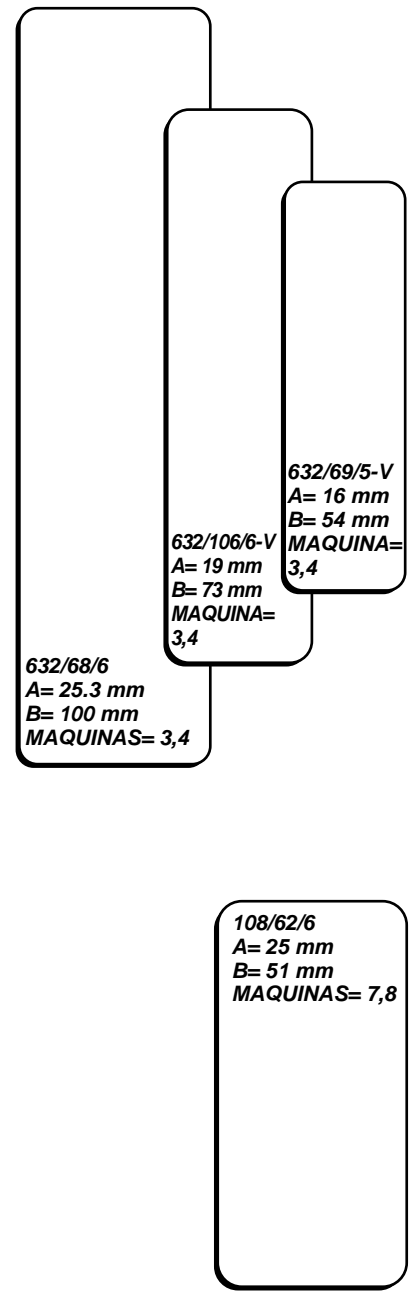

632/69/5-V
A= 16 mm
B= 54 mm
MAQUINA= 3,4

632/106/6-V
A= 19 mm
B= 73 mm
MAQUINA= 3,4

632/68/6
A= 25.3 mm
B= 100 mm
MAQUINAS= 3,4

108/62/6
A= 25 mm
B= 51 mm
MAQUINAS= 7,8



108/72/1
A= 111.2 mm
B= 189 mm
MAQUINAS= 10

108/84/6
A= 85 mm
B= 153 mm
MAQUINAS= 7,8,10

632/79/10
A= 62.5 mm
B= 112 mm
MAQUINAS= 3,4

108/57/2
A= 57 mm
B= 92 mm
MAQUINAS= 7,8

632/114/1
A= 67.9 mm
B= 122 mm
MAQUINAS= 3,4

632/64/15
A= 50 mm
B= 80 mm
MAQUINAS= 3,4

RECTANGULOS VERTICALES

108/57/2
A= 57 mm
B= 92 mm
MAQUINA= 7,8

108/54/2
A=40 mm
B= 60 mm
MAQUINAS= 7,8

108/74/3
A= 55 mm
B= 85 mm
MAQUINAS= 7,8,10

632/57/3
A= 25.4 mm
B= 38.1 mm
MAQUINAS= 3,4



108/64/6
A= 98.43 mm
B= 136 mm
MAQUINAS= 7,8,10

632/88/4
A= 107 mm
B= 141 mm
MAQUINAS= 3,4

732/79/3
A= 95.32 mm
B= 127 mm
MAQUINAS= 3,4

632/81/2
A= 97.99 mm
B= 127 mm
MAQUINA= 3,4

632/73/2
A= 88.5 mm
B= 115 mm
MAQUINAS= 3,4

632/82/8
A= 65 mm
B= 90 mm
MAQUINA= 3,4

632/61/1
A= 47.5 mm
B= 70 mm
MAQUINAS= 3,4

632/79/4
A= 46 mm
B= 65 mm
MAQUINAS= 3,4

108/54/1
A= 31 mm
B= 45 mm
MAQUINAS= 7,8

RECTANGULOS VERTICALES

632/64/2
A= 75 mm
B= 108 mm
MAQUINAS= 3,4

632/63/2
A= 76 mm
B= 101.5 mm
MAQUINAS= 3,4

108/69/5
A= 69.9 mm
B= 102 mm
MAQUINAS= 7,8

108/80/6
A= 60 mm
B= 77 mm
MAQUINAS= 7,8,10

108/63/1
A= 47 mm
B= 70 mm
MAQUINAS= 7,8

632/56/3
A= 31.8 mm
B= 44.5 mm
MAQUINAS= 3,4

632/71/7
A= 32 mm
B= 42 mm
MAQUINAS= 3,4



108/58/2
A= 88.9 mm
B= 110 mm
MAQUINAS= 7,8

108/66/4
A= 66.68 mm
B= 82 mm
MAQUINAS= 7,8,10

108/67/1
A= 50 mm
B= 56 mm
MAQUINAS= 7,8

632/66/10
A= 161 mm
B= 180 mm
MAQUINAS= 3,4

108/78/RM/6
A= 120 mm
B= 150 mm
MAQUINAS= 5,7,10

632/83/2
A= 100 mm
B= 120 mm
MAQUINAS= 3,4

108/82/RM/6
A= 83 mm
B= 100 mm
MAQUINAS= 5,7,10

108/62/3
A= 62.2 mm
B= 76.2 mm
MAQUINAS= 7,8



108/90/5
A= 139.7 mm
B= 152.4 mm
MAQUINAS= 7,8,10

108/90/RM/8
A= 139.7 mm
B= 140 mm
MAQUINAS= 5,7,10

632/99/1
A= 119.9 mm
B= 123.8 mm
MAQUINAS= 3,4

108/88/RM/5
A= 90 mm
B= 95 mm
MAQUINAS= 5,7,10

632/53/3
A= 63 mm
B= 69 mm
MAQUINA= 3,4

732/59/2
A= 69.8 mm
B= 73 mm
MAQUINAS= 3,4

108/62/4
A= 62.0 mm
B= 65.0 mm
MAQUINAS= 7,8



108/55/7
A= 84.2 mm
B= 84.2 mm
MAQUINAS= 7,8

108/78/7
A= 79.6 mm
B= 79.6 mm
MAQUINAS= 7,8,10

108/96/3
A= 149.4 mm
B= 149.4 mm
MAQUINAS= 7,8,10

108/69/1
A= 70 mm
B= 70 mm
MAQUINAS= 7,8

632/60/2
A= 12 mm
B= 12 mm
MAQUINAS= 3,4

632/59/7
A= 70 mm
B= 70 mm
MAQUINAS= 3,4

108/60/3
A= 60 mm
B= 60 mm
MAQUINAS= 7,8

632/69/3
A= 40 mm
B= 40 mm
MAQUINAS= 3,4

632/70/1
A= 31.7 mm
B= 31.7 mm
MAQUINAS= 3,4

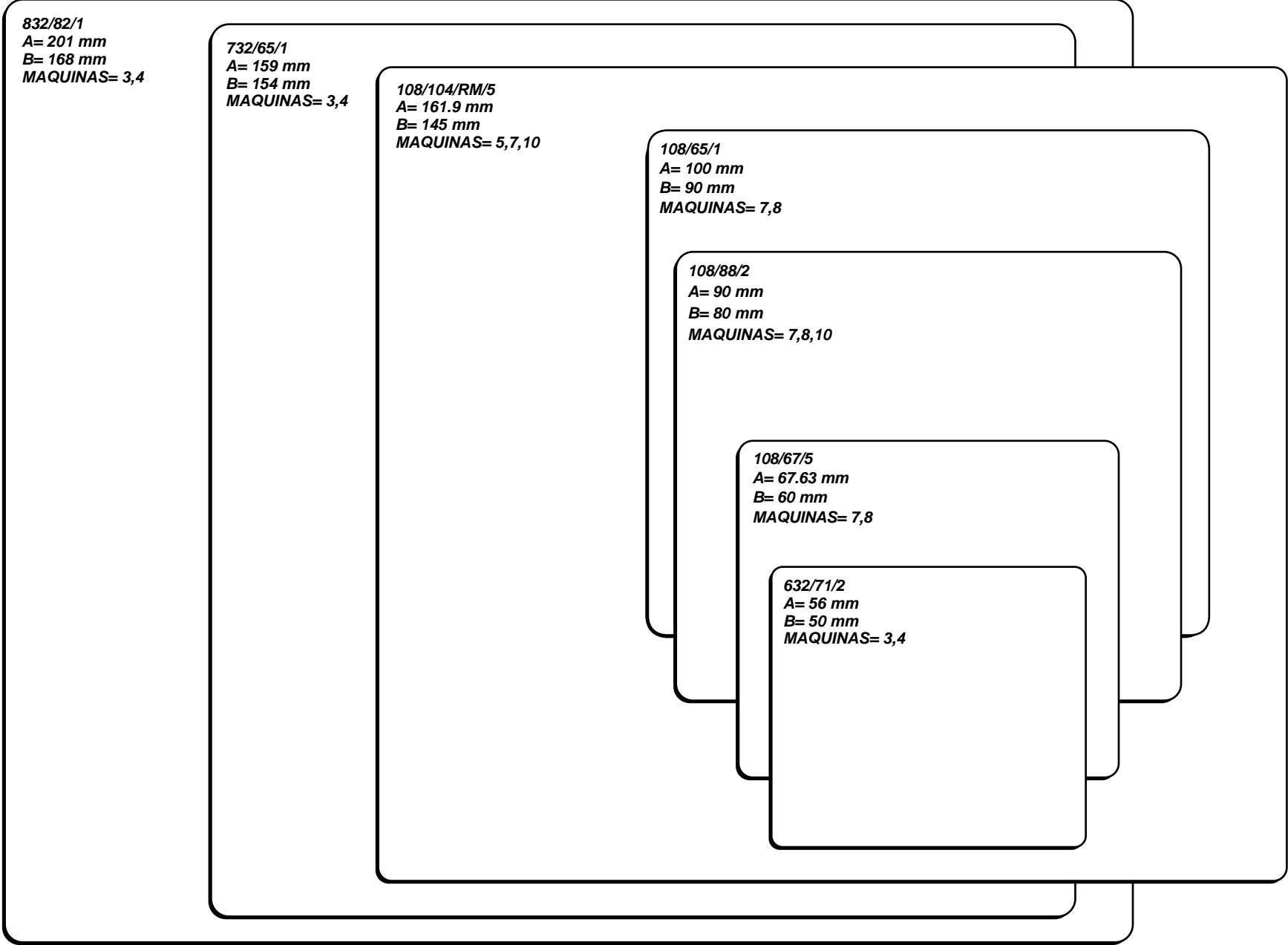



108/53/3
A= 165 mm
B= 145 mm
MAQUINAS= 7,8

108/90/RM/12
A= 139.7 mm
B= 120 mm
MAQUINAS= 5,7,10

108/66/RM/3
A= 101.6 mm
B= 88.9 mm
MAQUINAS= 5,7,10

632/57/4
A= 67.7 mm
B= 59.7 mm
MAQUINAS= 3,4

108/68/2
A= 50.8 mm
B= 44 mm
MAQUINAS= 7,8,10



108/104/RM/4
A= 160 mm
B= 135 mm
MAQUINAS= 5,7,10

632/68/11
A= 30.5 mm
B= 25.4 mm
MAQUINAS= 3,4

632/83/3
A= 100.3 mm
B= 80 mm
MAQUINAS= 3,4

108/62/1
A= 95 mm
B= 75 mm
MAQUINAS= 7,8

108/68/RM/9
A= 68.96 mm
B= 58 mm
MAQUINAS= 5,7,10

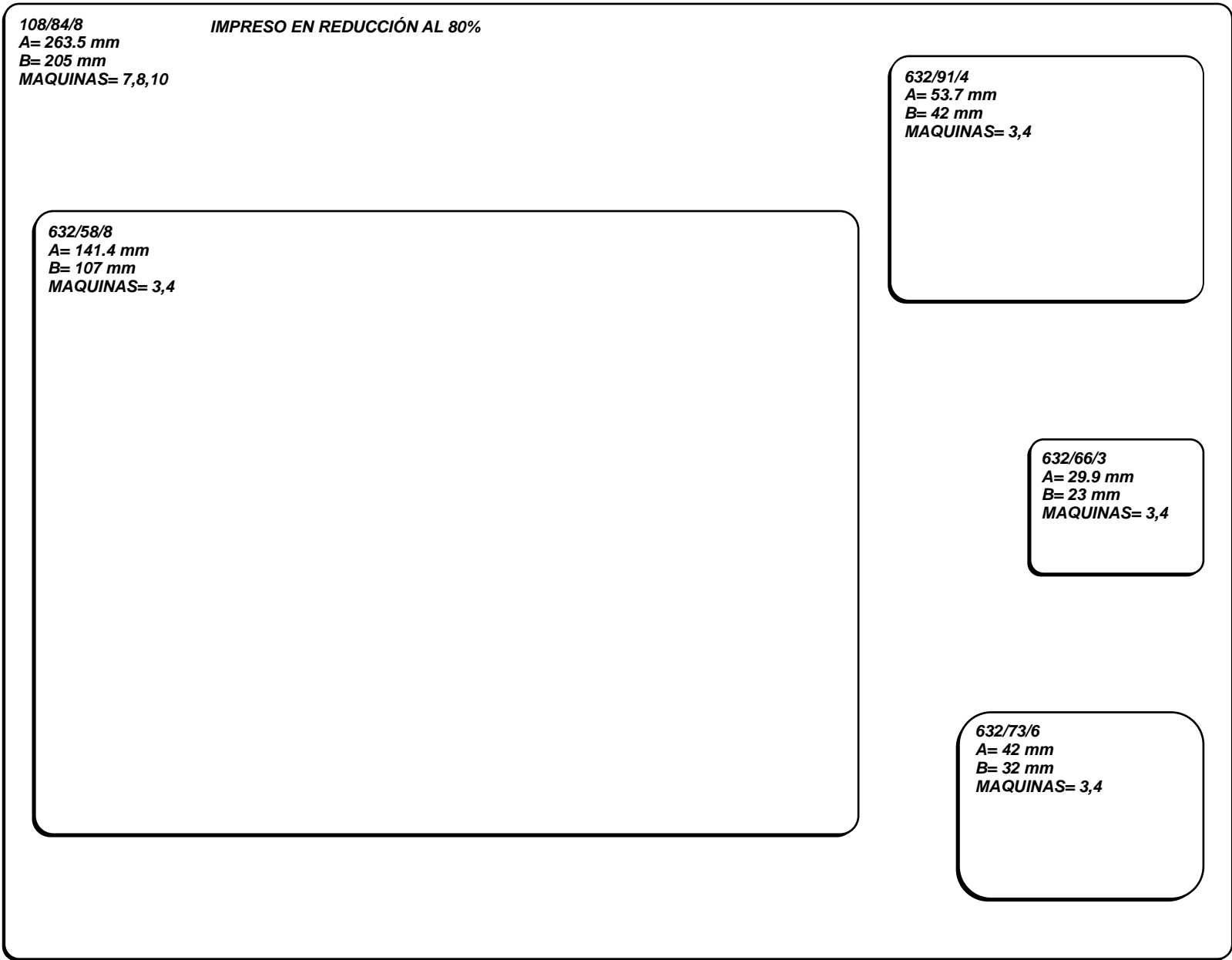



108/76/RM/4
A= 238.3 mm
B= 177 mm
MAQUINAS= 5,10

108/75/RM/3
A= 115.887 mm
B= 85 mm
MAQUINAS= 5,7,10

108/67/6
A= 67.73 mm
B= 50 mm
MAQUINAS= 7,8

632/76/7
A= 60 mm
B= 45 mm
MAQUINAS= 3,4

632/66/9
A= 29.9 mm
B= 22 mm
MAQUINAS= 3,4



108/75/4
A= 235 mm
B= 170 mm
MAQUINAS= 7,8

632/64/1
A= 157 mm
B= 110 mm
MAQUINAS= 3,4

108/84/3
A= 130 mm
B= 90 mm
MAQUINAS= 7,8,10

108/75/RM/2
A= 115.89 mm
B= 80 mm
MAQUINAS= 5,7,10

732/81/1
A= 98.4 mm
B= 69.9 mm
MAQUINAS= 3,4

632/63/1
A= 76 mm
B= 55 mm
MAQUINAS= 3,4

632/59/5
A= 70 mm
B= 50 mm
MAQUINAS= 3,4

632/76/1
A= 60 mm
B= 42 mm
MAQUINAS= 3,4

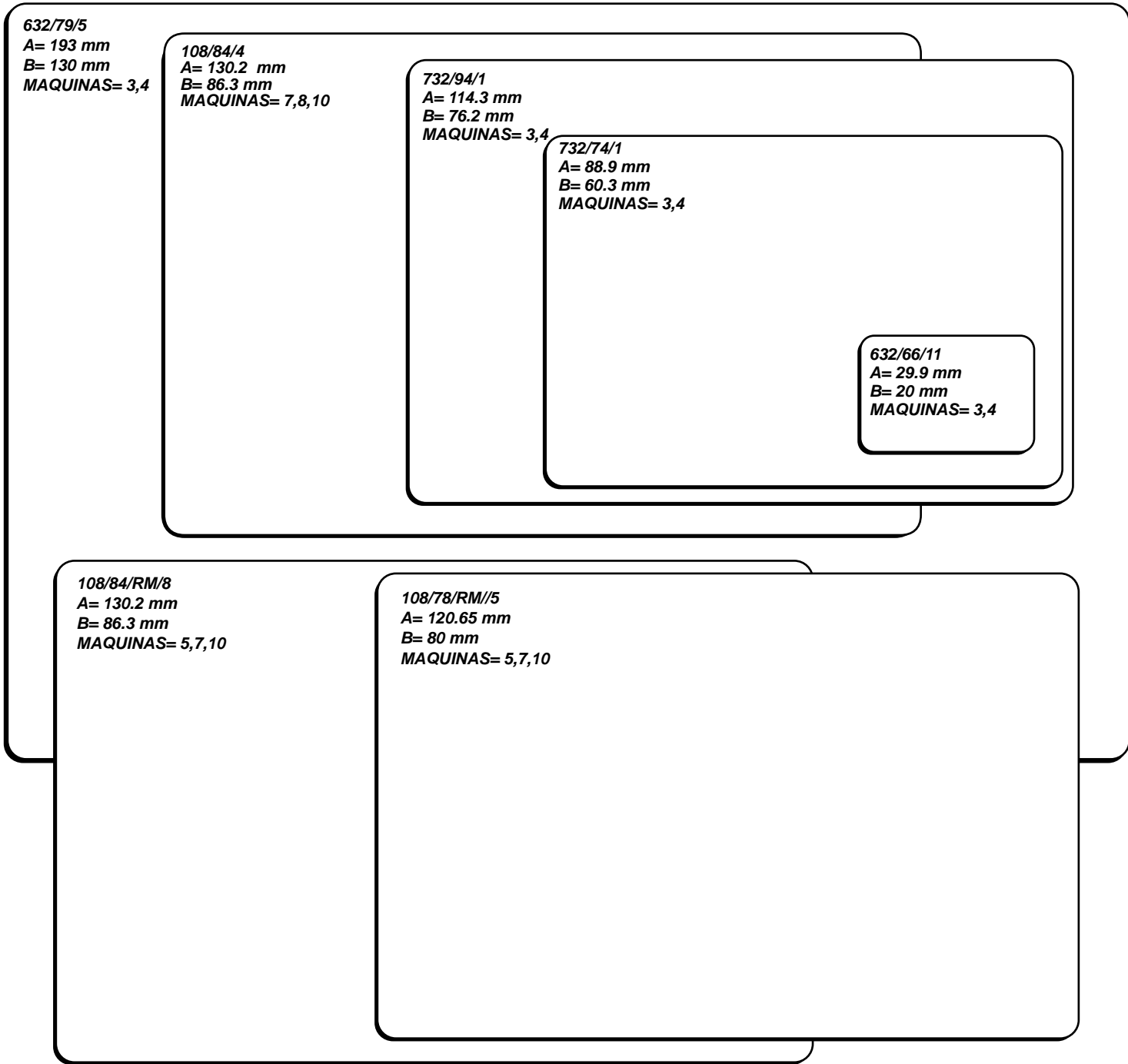



732/62/2
A= 151.4 mm
B= 97 mm
MAQUINAS= 3,4

732/59/1
A= 69.9 mm
B= 44.5 mm
MAQUINAS= 3,4

632/61/5
A= 47 mm
B= 30 mm
MAQUINAS= 3,4

632/66/2
A= 38 mm
B= 25 mm
MAQUINAS= 3,4



632/76/3
A= 186.3 mm
B= 110 mm
MAQUINAS= 3,4

632/66/12
A= 161 mm
B= 100 mm
MAQUINAS= 3,4

108/74/2
A= 114.3 mm
B= 71 mm
MAQUINAS= 7,8,10

108/54/6
A= 82.5 mm
B= 48 mm
MAQUINAS= 7,8

632/59/6
A= 70 mm
B= 41 mm
MAQUINAS= 3,4

632/82/1
A= 65 mm
B= 40 mm
MAQUINAS= 3,4

632/63/3
A= 36 mm
B= 22 mm
MAQUINAS= 3,4

632/61/9
A= 35 mm
B= 20 mm
MAQUINAS= 3,4

632/58/3
A= 33 mm
B= 20 mm
MAQUINAS= 3,4

632/87/2
A= 105.3 mm
B= 60 mm
MAQUINAS= 3,4

632/82/6
A= 99 mm
B= 57 mm
MAQUINAS= 3,4



108/88/5
A= 276.2 mm
B= 149 mm
MAQUINAS= 7,8,10

IMPRESO EN REDUCCION AL 90%

108/69/3
A= 213 mm
B= 115 mm
MAQUINAS= 7,8

108/65/3
A= 203.2 mm
B= 110 mm
MAQUINAS= 7,8

108/60/1
A= 44.5 mm
B= 24 mm
MAQUINAS= 7,8

732/58/1
A= 141.5 mm
B= 75 mm
MAQUINAS= 3,4

108/64/RM//8
A= 98.5 mm
B= 52 mm
MAQUINAS= 5,7,10

108/64/1
A= 98.4 mm
B= 52 mm
MAQUINAS= 7,8,10

632/83/4
A= 100 mm
B= 35 mm
MAQUINAS= 3,4

632/69/1
A= 83 mm
B= 45 mm
MAQUINAS= 3,4

632/76/5
A= 60 mm
B= 32 mm
MAQUINAS= 3,4



108/82/5
A= 257.35 mm
B= 135 mm
MAQUINAS= 7,8,10

632/99/5
A= 243 mm
B= 125 mm
MAQUINAS= 3,4

108/102/1
A= 319.5 mm
B= 160.5 mm
MAQUINAS= 7,8

IMPRESO EN REDUCCION AL 75%

108/65/2
A= 203 mm
B= 105 mm
MAQUINAS= 7,8

632/72/1
A= 176 mm
B= 90 mm
MAQUINAS= 3,4

108/90/2
A= 139.7 mm
B= 70 mm
MAQUINAS= 7,8,10

108/74/1
A= 114.4 mm
B= 57.15 mm
MAQUINAS= 7,8,10

632/73/1
A= 88 mm
B= 45 mm
MAQUINAS= 3,4

108/78/RM//1
A= 79.5 mm
B= 40 mm
MAQUINAS= 5,7,10

632/81/3-V
A= 64 mm
B= 32 mm
MAQUINAS= 3,4

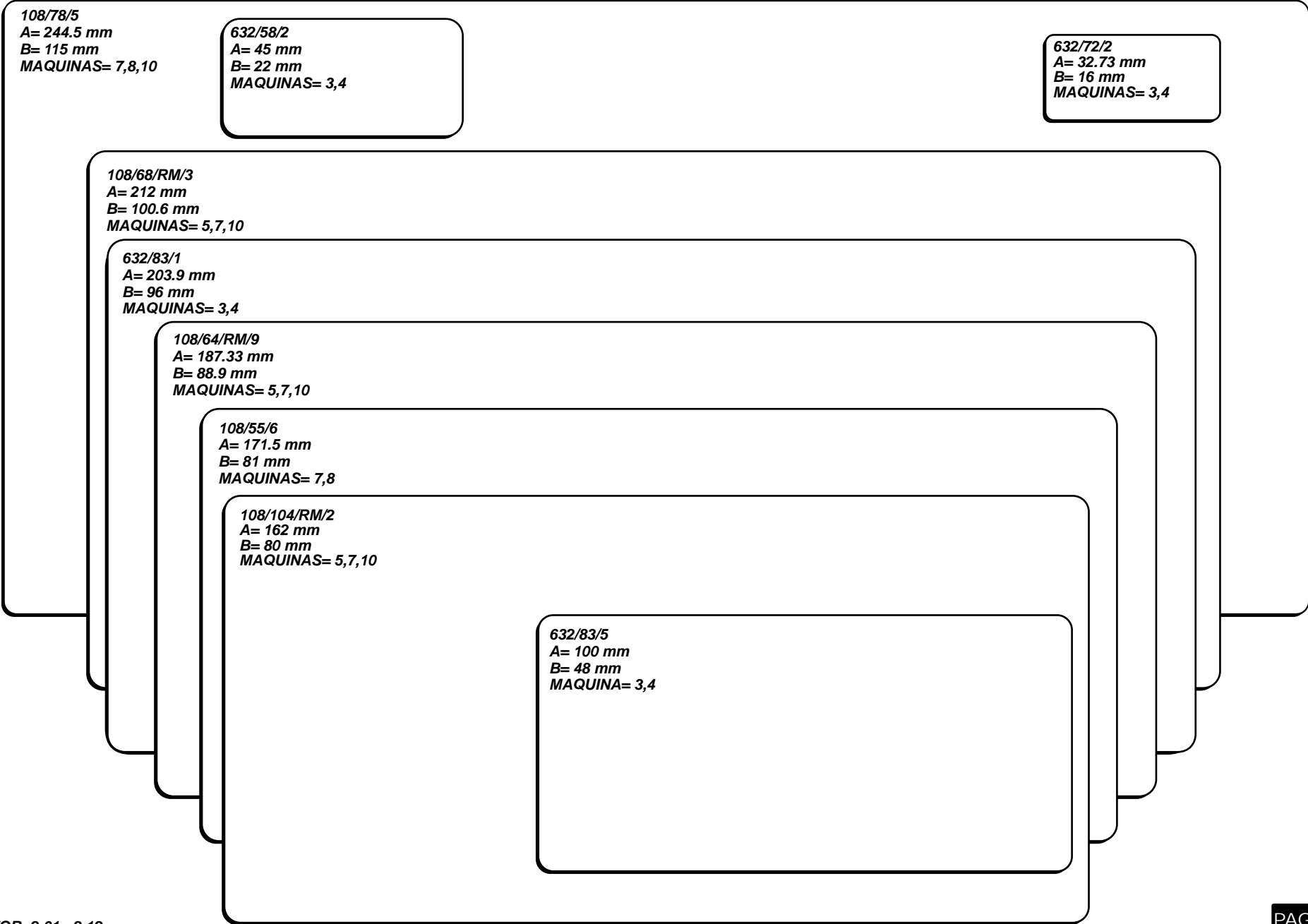



108/74/5
A= 231 mm
B= 108 mm
MAQUINAS= 7,8,10

632/56/5
A= 136.5 mm
B= 64 mm
MAQUINAS= 3,4

108/69/8
A= 106.5 mm
B= 50 mm
MAQUINAS= 7,8

108/64/RM/4
A= 64.6 mm
B= 30 mm
MAQUINAS= 5,7,10

632/58/6
A= 69.14 mm
B= 32 mm
MAQUINAS= 3,4

108/90/RM/4
A= 139 mm
B= 64.5 mm
MAQUINAS= 5,7,10

632/88/5
A= 106.5 mm
B= 50 mm
MAQUINAS= 3,4



RECTANGULOS HORIZONTALES

108/96/RM/1
A= 149 mm
B= 68 mm
MAQUINAS= 5,7,10

632/58/11
A= 141.6 mm
B= 63 mm
MAQUINAS= 3,4

108/66/1
A= 101.6 mm
B= 44.5 mm
MAQUINAS= 7,8,10

632/63/7
A= 36.1 mm
B= 16 mm
MAQUINAS= 3,4

632/63/4
A= 75 mm
B= 34 mm
MAQUINAS= 3,4

632/57/1
A= 44 mm
B= 20 mm
MAQUINAS= 3,4

632/73/3
A= 87.8 mm
B= 39 mm
MAQUINAS= 3,4

632/61/8
A= 149 mm
B= 68 mm
MAQUINA= 3,4

108/66/RM/6
A= 99 mm
B= 45 mm
MAQUINAS= 5,7,10

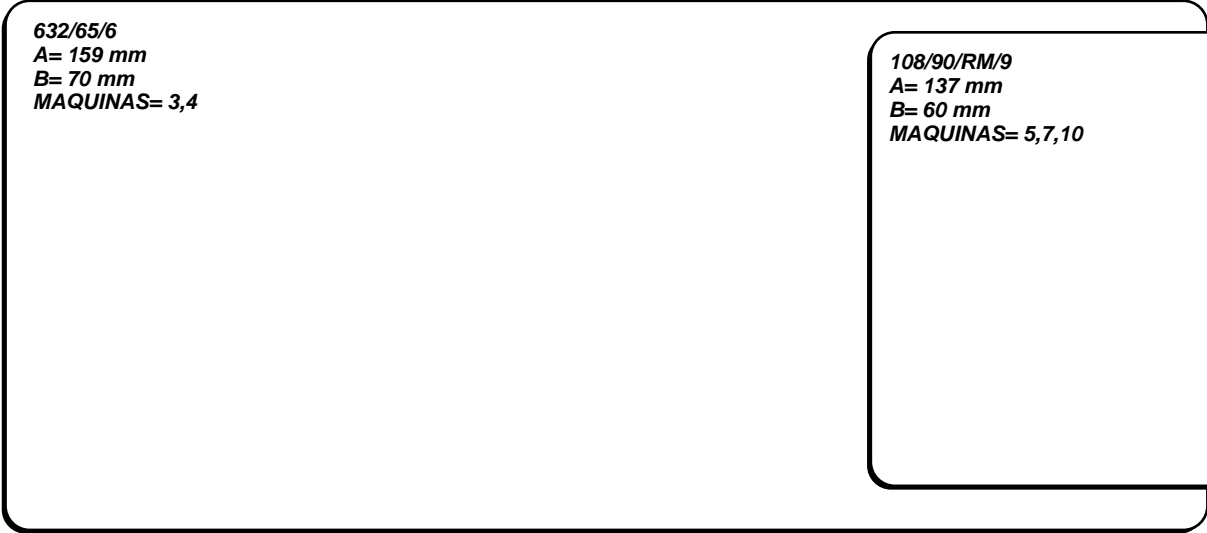
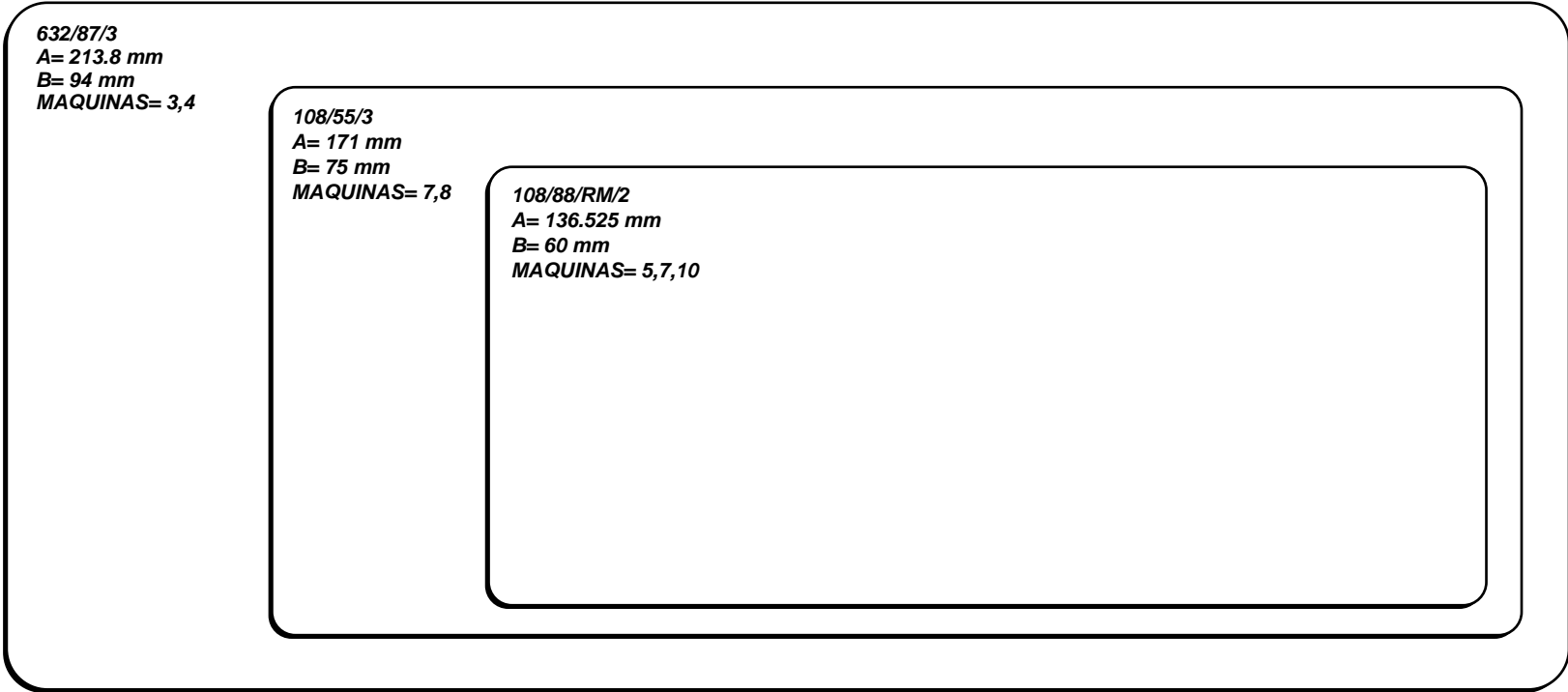

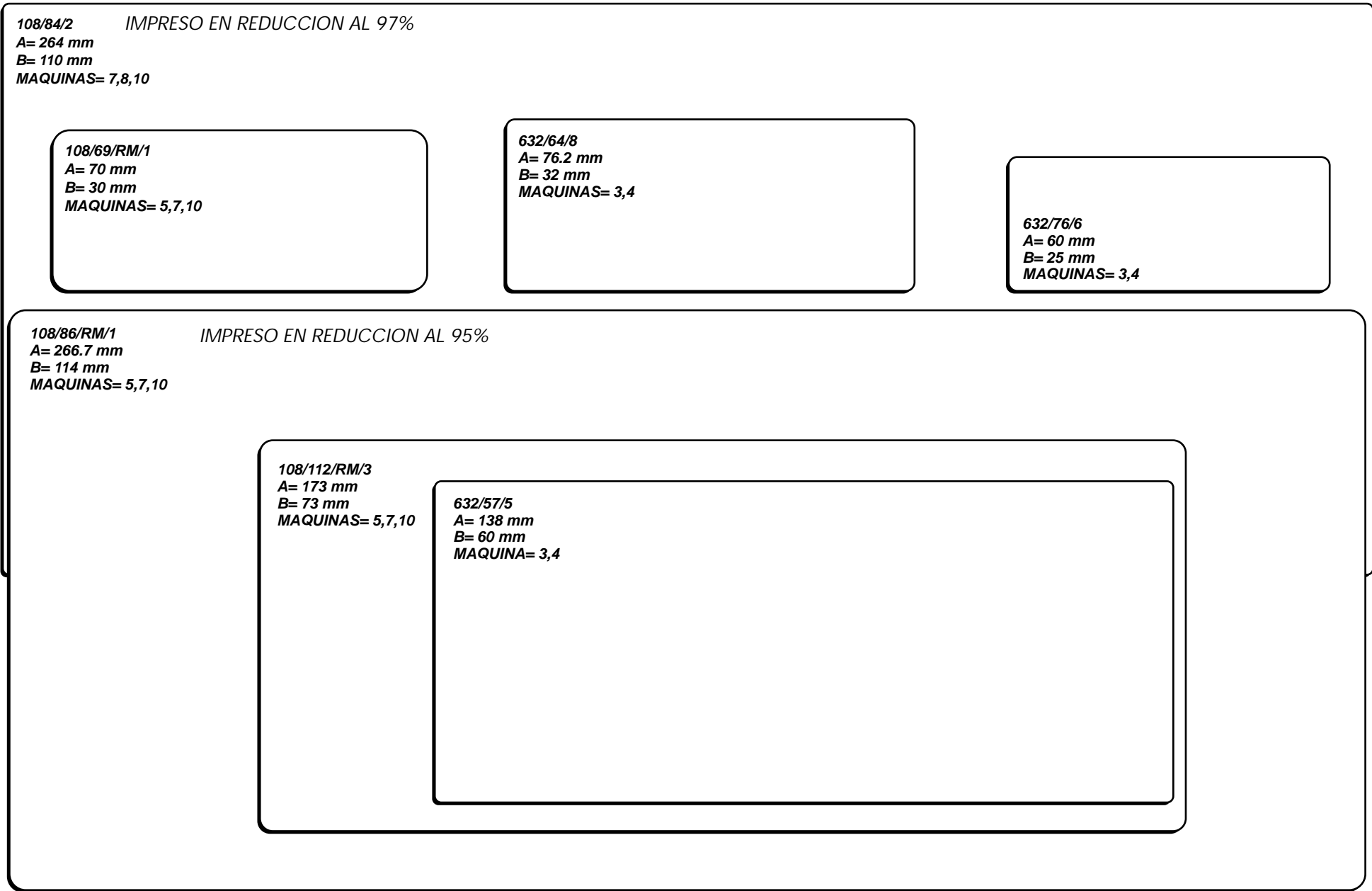



108/84/1 IMPRESO EN REDUCCION AL 97%
A= 263 mm
B= 108 mm
MAQUINAS= 7,8,10

108/81/3 (1 CAV.)
108/81/2 (2 CAV.)
A= 252 mm
B= 103 mm
MAQUINAS= 7,8

108/90/1
A= 139.7 mm
B= 57 mm
MAQUINAS= 7,8,10

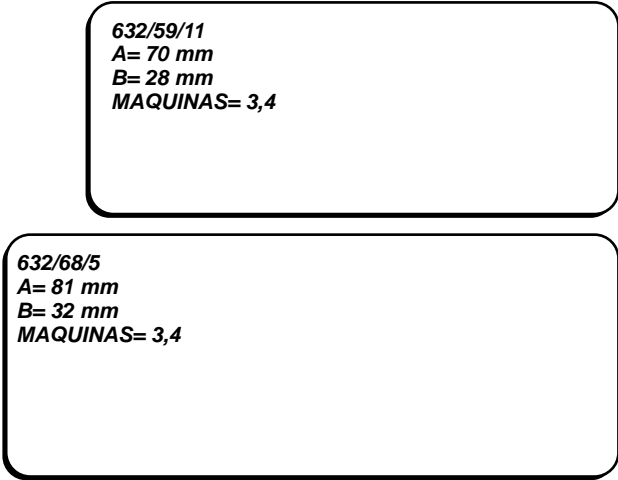
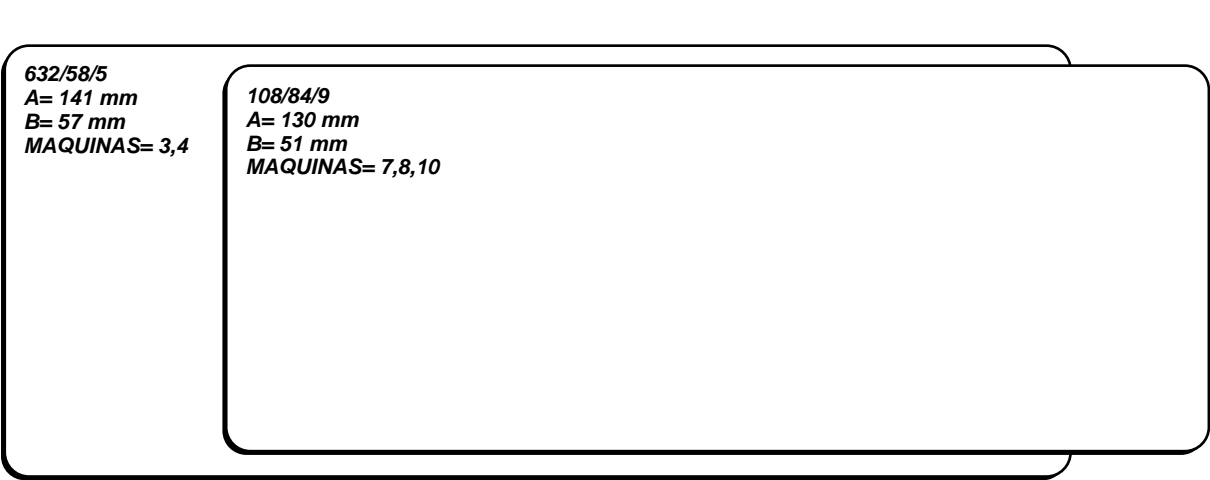
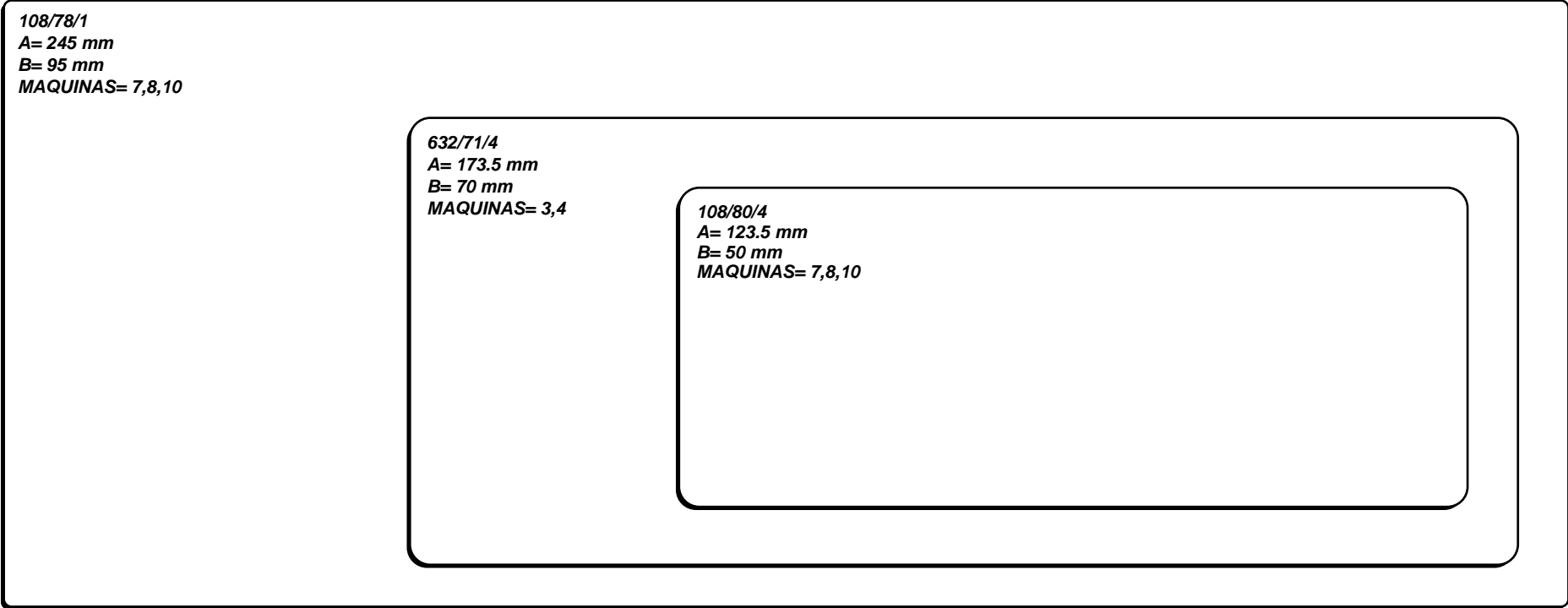

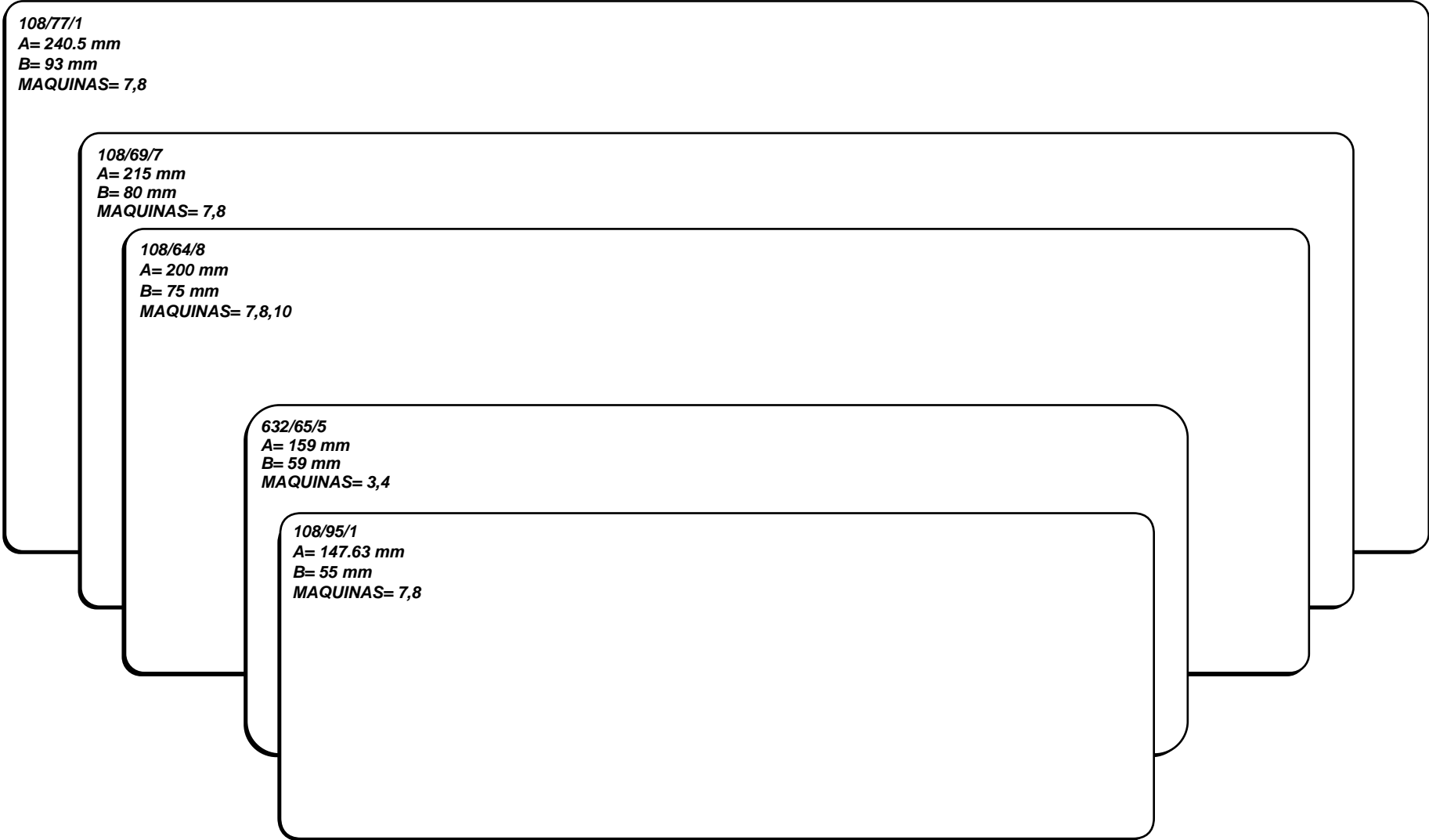



IMPRESO EN REDUCCION AL 85%

108/102/2*
A= 314 mm
B= 114 mm
MAQUINAS= 7,8

632/65/1
A= 159 mm
B= 58 mm
MAQUINAS= 3,4

632/70/2
A= 84 mm
B= 30 mm
MAQUINAS= 3,4

108/81/4
A= 254 mm
B= 96 mm
MAQUINAS= 7,8

108/71/2
A= 222.2 mm
B= 80 mm
MAQUINAS= 7,8

632/74/4
A= 181 mm
B= 65 mm
MAQUINAS= 3,4



RECTANGULOS HORIZONTALES

108/104/RM//1B
A= 162 mm
B= 57 mm
MAQUINAS= 5,7,10

108/74/RM/7
A= 114.3 mm
B= 40 mm
MAQUINAS= 5,7,10

632/76/2
A= 91 mm
B= 32 mm
MAQUINAS= 3,4

632/106/3
A= 129 mm
B= 43 mm
MAQUINAS= 3,4

632/64/7
A= 76.6 mm
B= 27 mm
MAQUINAS= 3,4

632/66/6
A= 161.5 mm
B= 57 mm
MAQUINAS= 3,4

632/106/8-V
A= 63 mm
B= 22 mm
MAQUINAS= 3,4

108/82/RM/4
A= 62 mm
B= 22 mm
MAQUINAS= 5,7,10



108/92/1 IMPRESO EN REDUCCION AL 90%
A= 289 mm
B= 95 mm
MAQUINAS= 7,8,10

632/67/6
A= 80.5 mm
B= 27 mm
MAQUINA= 3,4

108/53/1
A= 165 mm
B= 57 mm
MAQUINAS= 7,8

632/88/2
A= 106.5 mm
B= 36 mm
MAQUINAS= 3,4

632/64/10
A= 76 mm
B= 25 mm
MAQUINAS= 3,4

632/84/1
A= 66.5 mm
B= 22 mm
MAQUINAS= 3,4

108/78/6
A= 244.5 mm
B= 85 mm
MAQUINAS= 7,8,10

108/84/RM/6
A= 129 mm
B= 43 mm
MAQUINAS= 5,7,10

108/90/RM/7
A= 92 mm
B= 32 mm
MAQUINAS=5, 7,10

108/60/11
A= 92 mm
B= 32 mm
MAQUINAS= 7,8



108/147/1 IMPRESO EN REDUCCION AL 55%

A= 464 mm

B= 142 mm

MAQUINAS= 7,8

108/102/4 IMPRESO EN REDUCCION AL 80%

A= 320.6 mm

B= 100 mm

MAQUINAS= 7,8

632/82/4

A= 201.3 mm

B= 62 mm

MAQUINAS= 3,4

632/78/1

A= 190 mm

B= 62 mm

MAQUINAS= 3,4

632/99/2

A= 120.2 mm

B= 39 mm

MAQUINAS= 3,4

108/64/RM/13

A= 98 mm

B= 32 mm

MAQUINAS= 5,7,10

108/64/7

A= 200 mm

B= 62 mm

MAQUINAS= 7,8,10

108/64/RM/3

A= 190 mm

B= 62 mm

MAQUINAS= 5,7,10

632/65/4

A= 158.9 mm

B= 50 mm

MAQUINAS= 3,4

108/90/4

A= 139 mm

B= 42 mm

MAQUINAS= 7,8,10

108/112/RM/2

A= 115 mm

B= 35 mm

MAQUINAS= 5,7,10



108/147/2 IMPRESO EN REDUCCIÓN AL 55%

A= 463 mm
B= 134 mm
MAQUINAS= 7,8

108/80/5
A= 250.5 mm
B= 71 mm
MAQUINAS= 7,8,10

108/64/3
A= 200 mm
B= 58 mm
MAQUINAS= 7,8,10

108/50/1
A= 76 mm
B= 22 mm
MAQUINAS= 7,8

108/55/2
A= 83.8 mm
B= 24 mm
MAQUINAS= 7,8

632/79/9
A= 95.3 mm
B= 28 mm
MAQUINAS= 3,4

632/70/3
A= 83.8 mm
B= 24 mm
MAQUINAS= 3,4

108/81/5
A= 252 mm
B= 73 mm
MAQUINAS= 7,8

108/59/1
A= 184.15 mm
B= 53.5 mm
MAQUINAS= 7,8

108/78/RM/7
A= 120.2 mm
B= 35 mm
MAQUINAS= 5,7,10

108/82/RM/1
A= 83.8 mm
B= 24 mm
MAQUINAS= 5,7,10

632/68/7
A= 53 mm
B= 15 mm
MAQUINAS= 3,4

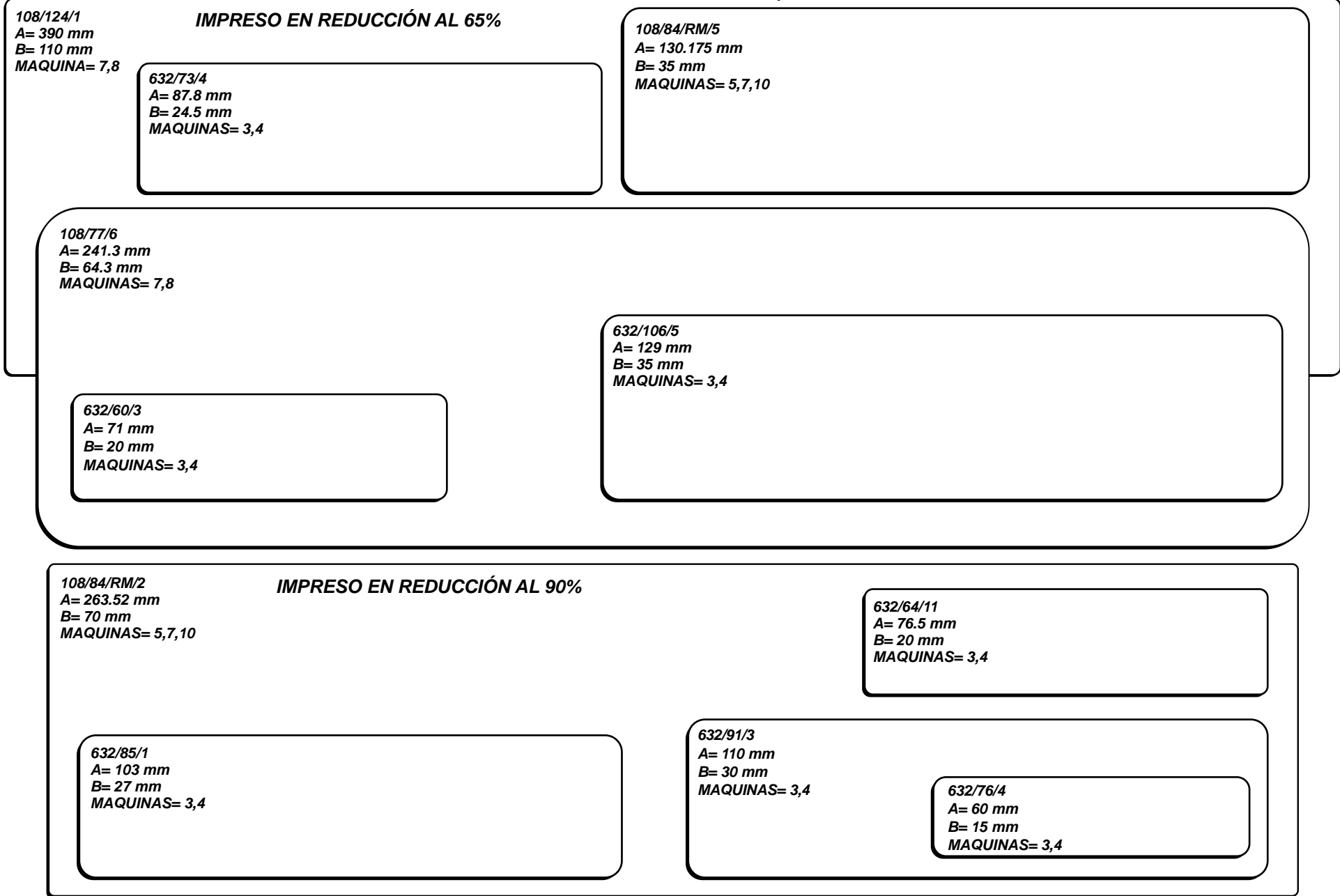



108/80/3
A= 251.3 mm
B= 64 mm
MAQUINAS= 7,8,10

108/66/RM/1
A= 101.6 mm
B= 25.3 mm
MAQUINAS= 5,7,10

632/86/2
A= 104 mm
B= 25 mm
MAQUINAS= 3,4

108/88/RM/1
A= 90 mm
B= 22 mm
MAQUINAS= 5,7,10

632/75/1
A= 90 mm
B= 22 mm
MAQUINAS= 3,4

632/67/4
A= 80.5 mm
B= 20 mm
MAQUINAS= 3,4

632/64/12
A= 76.6 mm
B= 18 mm
MAQUINAS= 3,4



108/102/3 *IMPRESO EN REDUCCION AL 80%*
A= 320.6 mm
B= 73 mm
MAQUINAS= 7,8

108/75/3
A= 235 mm
B= 47 mm
MAQUINAS= 7,8

108/50/3
A= 155.6 mm
B= 35 mm
MAQUINAS= 7,8

108/64/RM/5
A= 199 mm
B= 44 mm
MAQUINAS= 5,7,10

108/96/1
A= 149.22 mm
B= 30 mm
MAQUINAS= 7,8,10



108/90/6 IMPRESO EN REDUCCION AL 90%
A= 282.57 mm
B= 50 mm
MAQUINAS= 7,8,10

632/66/8
A= 161 mm
B= 31 mm
MAQUINAS= 3,4

632/99/3
A= 243.7 mm
B= 42 mm
MAQUINAS= 3,4

108/55/4
A= 171.5 mm
B= 30 mm
MAQUINAS= 7,8

108/80/RM/2
A= 123.3 mm
B= 24 mm
MAQUINAS= 5,7,10

108/124/2 IMPRESO EN REDUCCION AL 65%
A= 390.5 mm
B= 76 mm
MAQUINA= 7,8

108/60/10
A= 187.3 mm
B= 31 mm
MAQUINAS= 7,8

632/56/2
A= 31.7 mm
B= 6 mm
MAQUINAS= 3,4

632/86/1
A= 104 mm
B= 18 mm
MAQUINAS= 3,4

108/68/RM/1
A= 104 mm
B= 18 mm
MAQUINAS= 5,7,10



108/82/RM/5
A= 257.17 mm
B= 13 mm
MAQUINAS= 5,7,10

108/82/3 - 108/82/4
A= 257.1 mm
B= 40 mm
MAQUINAS= 7,8,10

108/58/3
A= 180 mm
B= 28 mm
MAQUINA= 7,8

108/82/RM/3
A= 127 mm
B= 18 mm
MAQUINAS= 5,7,10

108/100/RM/1
A= 314.5 mm
B= 50 mm
MAQUINA= 5,10

IMPRESO EN REDUCCION AL 80%

108/54/3
A= 168.3 mm
B= 24 mm
MAQUINAS= 7,8

108/75/5
A= 234 mm
B= 30 mm
MAQUINAS= 7,8

632/88/1
A= 106.5 mm
B= 10 mm
MAQUINAS= 3,4

108/74/7
A= 231.7 mm
B= 30 mm
MAQUINAS= 7,8,10

108/68/RM/8
A= 212 mm
B= 13 mm
MAQUINAS= 5,7,10

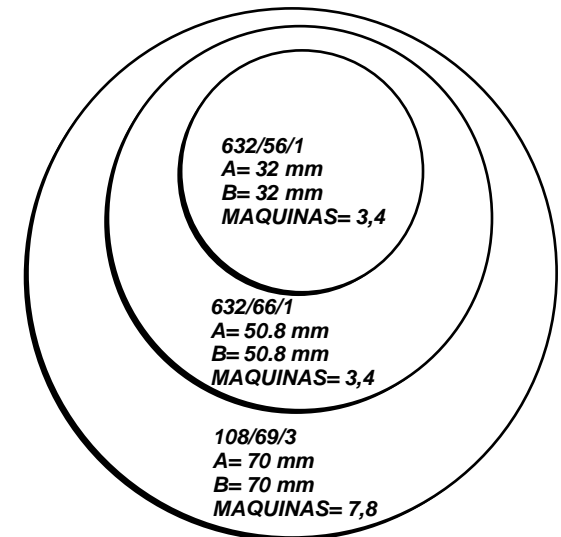
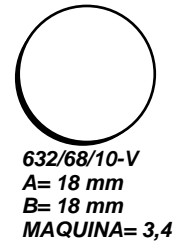
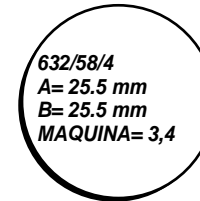
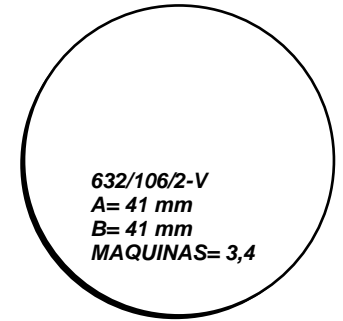
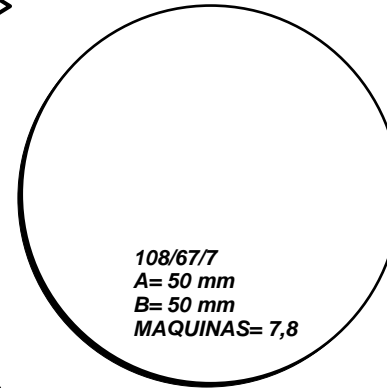
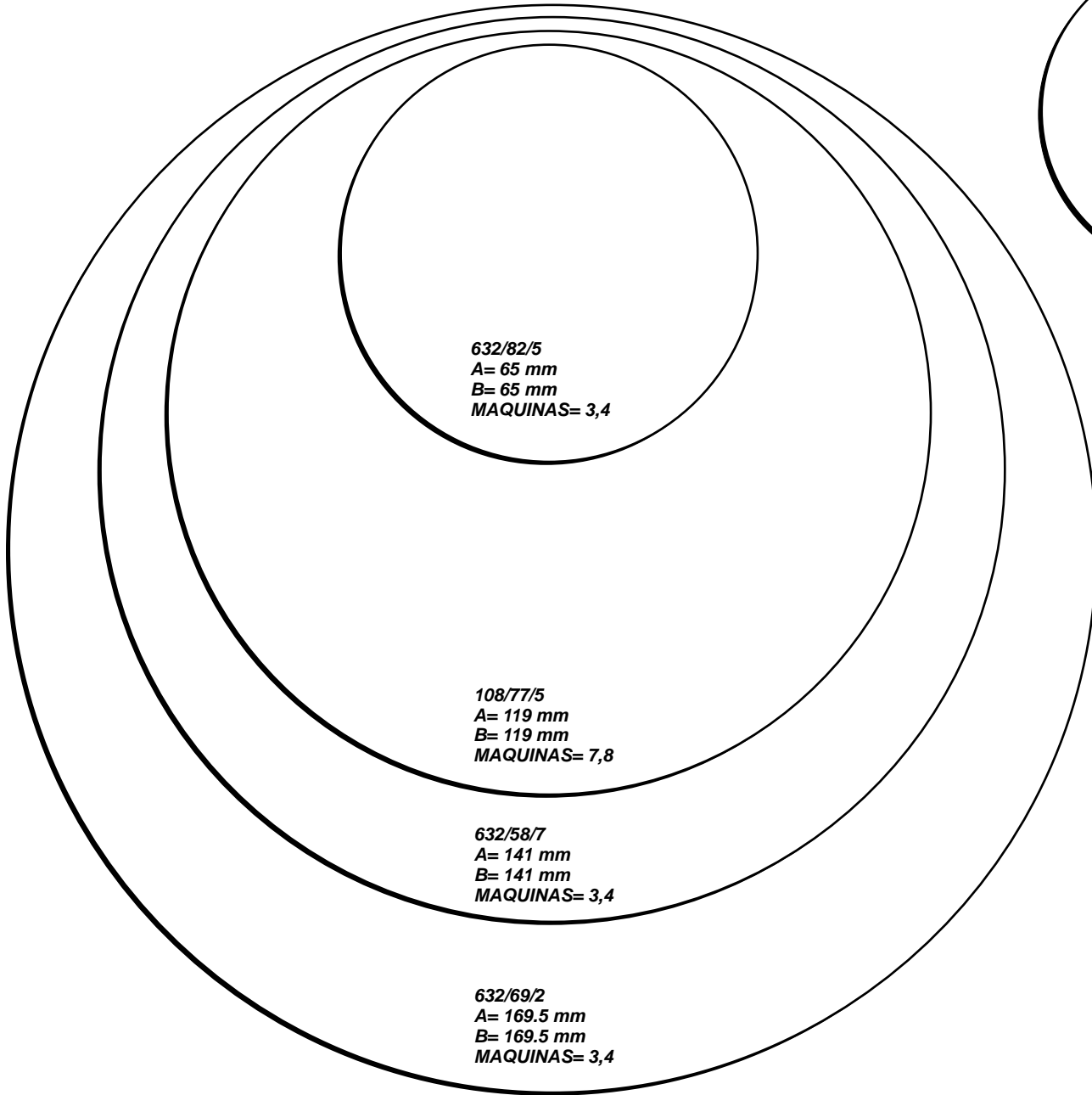

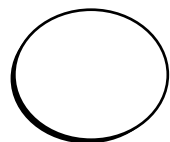

632/63/6
A= 20.3 mm
B= 17.2 mm
MAQUINAS= 3,4



632/59/1
A= 18 mm
B= 10 mm
MAQUINAS= 3,4

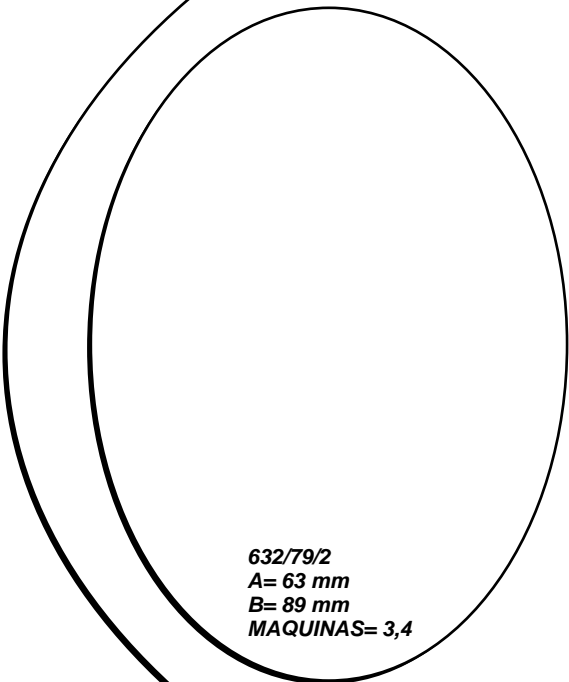

632/79/2
A= 63 mm
B= 89 mm
MAQUINAS= 3,4

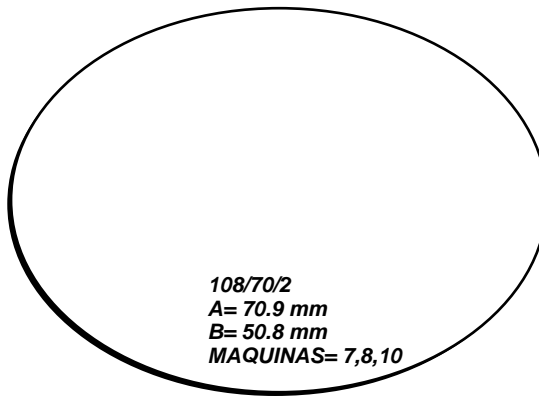

108/70/2
A= 70.9 mm
B= 50.8 mm
MAQUINAS= 7,8,10

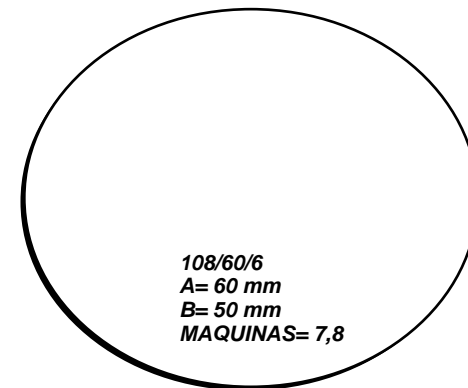

108/60/6
A= 60 mm
B= 50 mm
MAQUINAS= 7,8

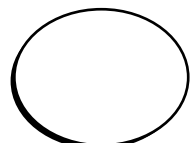

632/62/1
A= 23 mm
B= 18 mm
MAQUINAS= 3,4



108/65/RM/1
A= 100 mm
B= 73 mm
MAQUINAS= 5,7,10

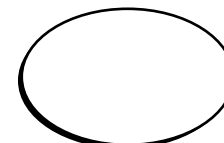

632/62/2
A= 28 mm
B= 18 mm
MAQUINAS= 3,4

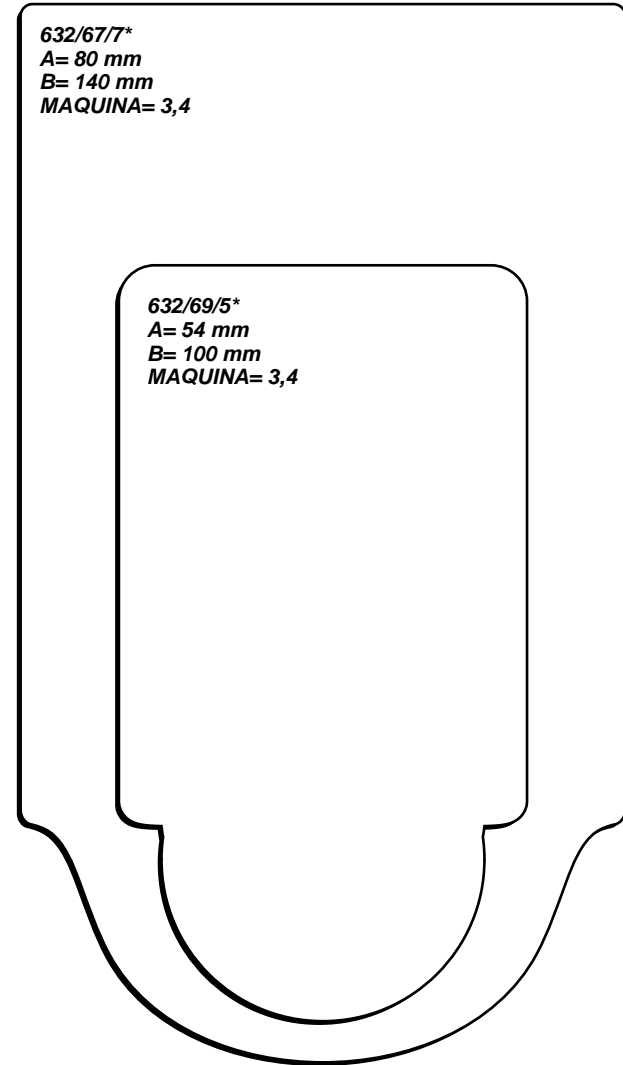
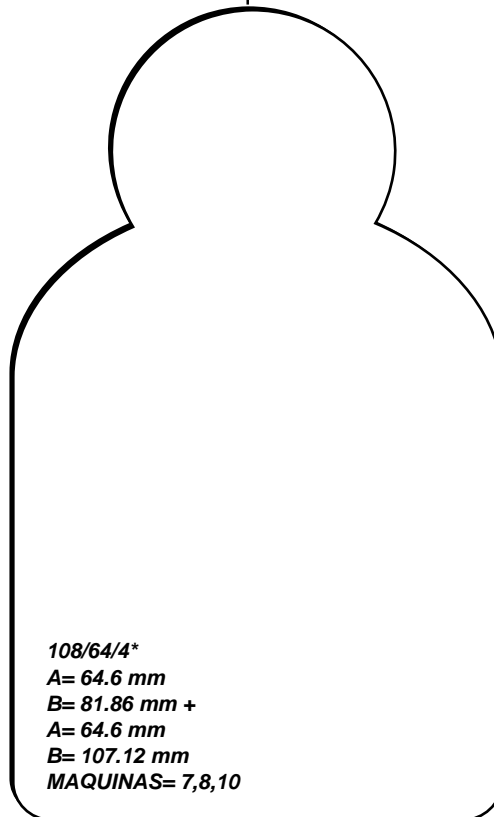
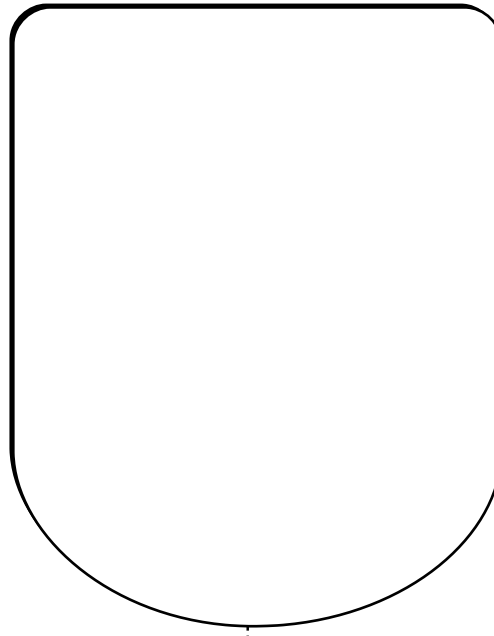
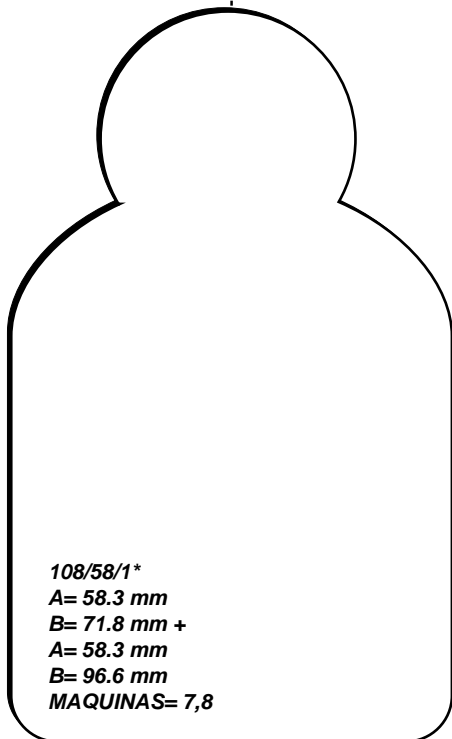
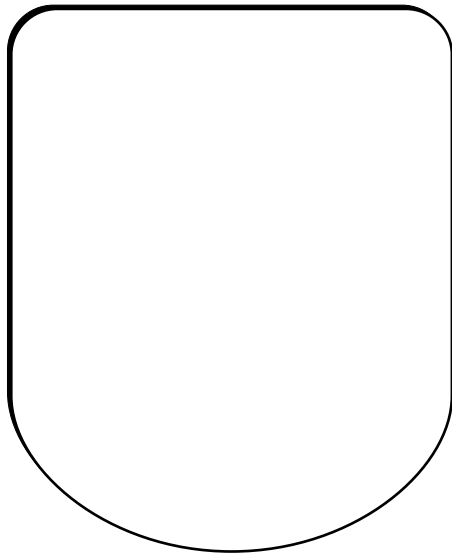

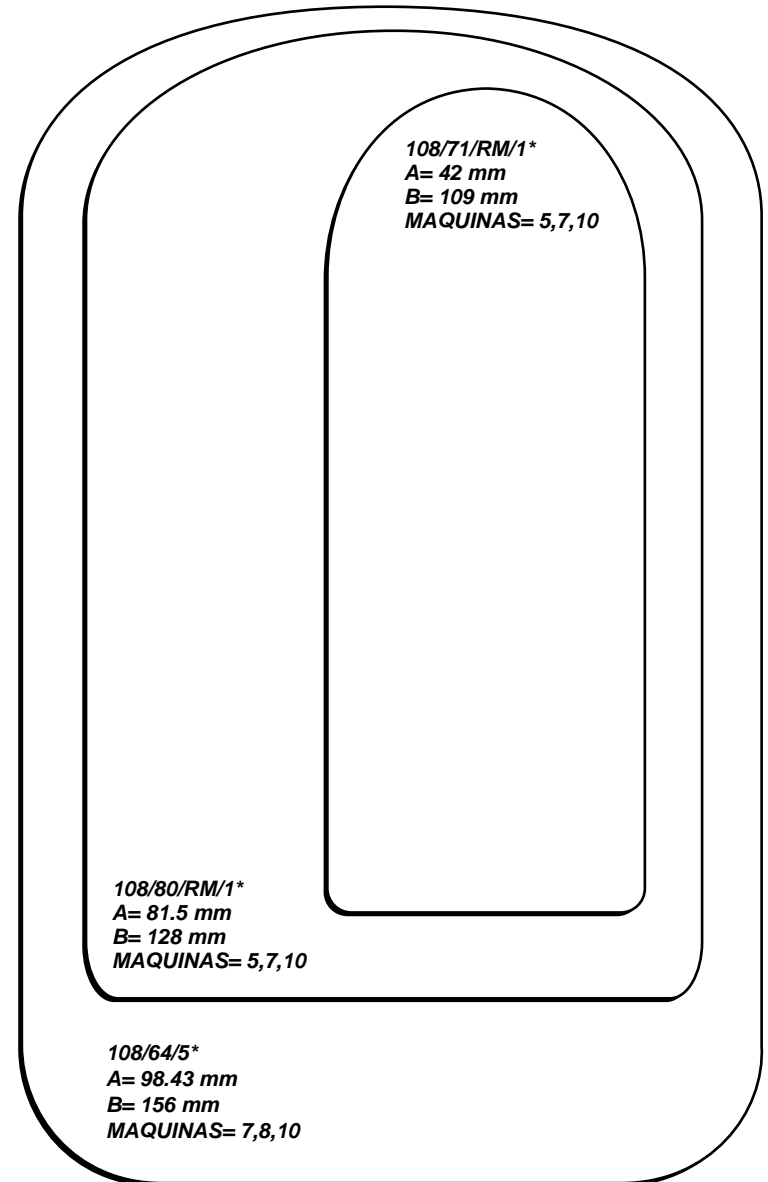
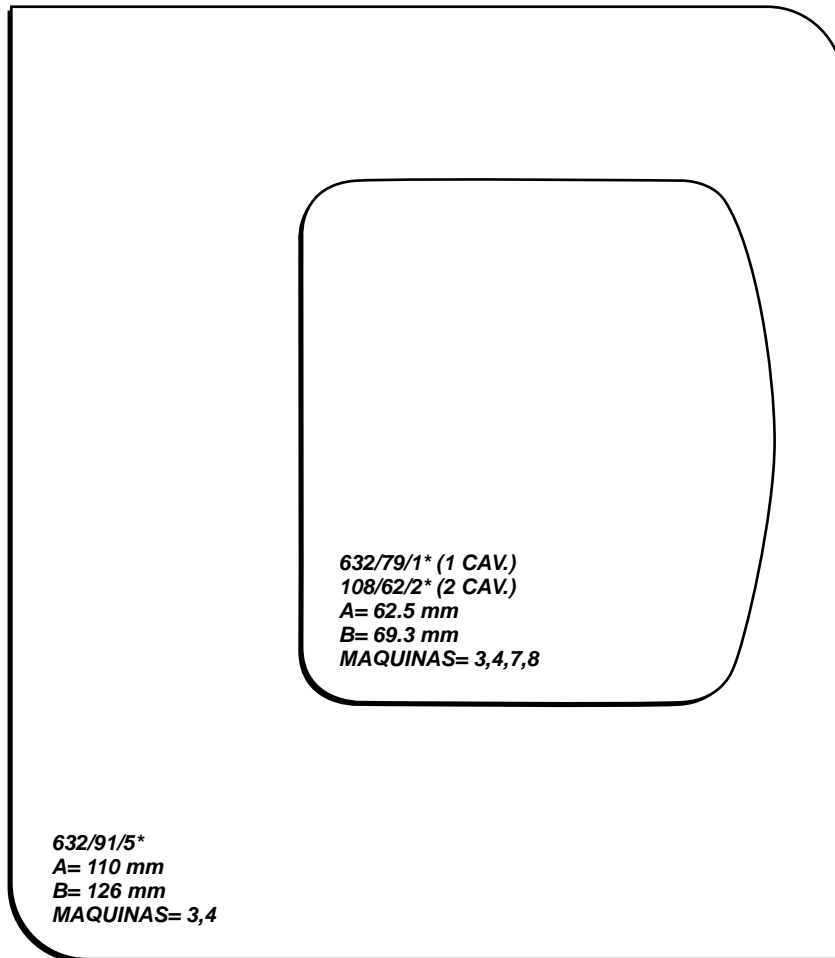

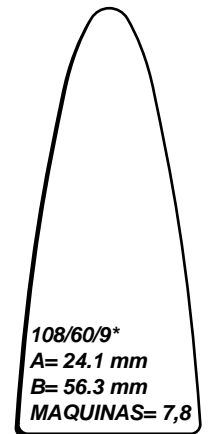
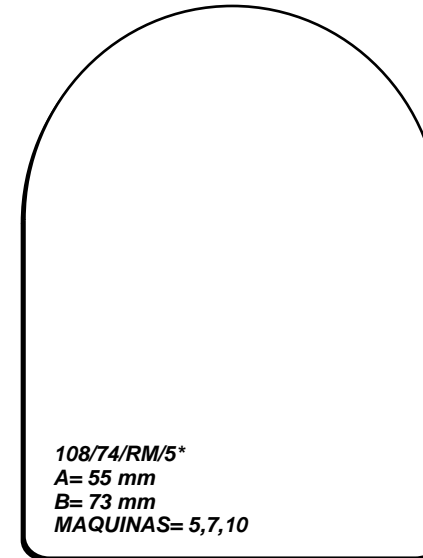
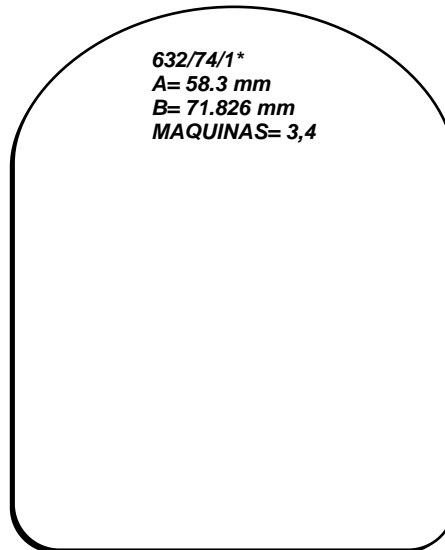
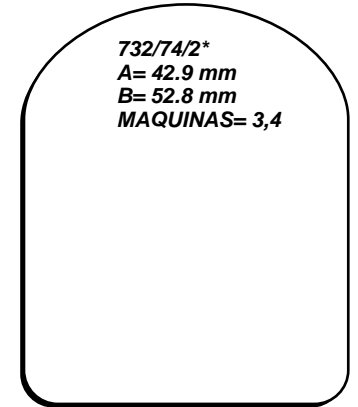
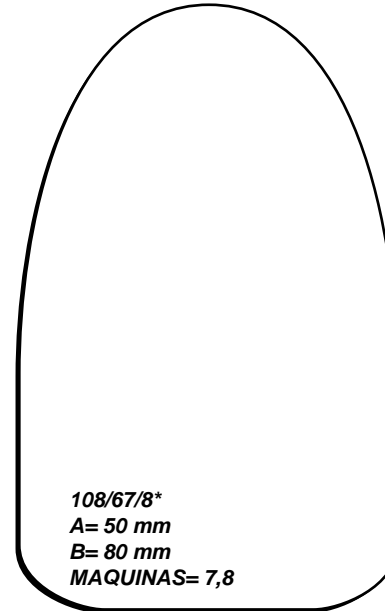
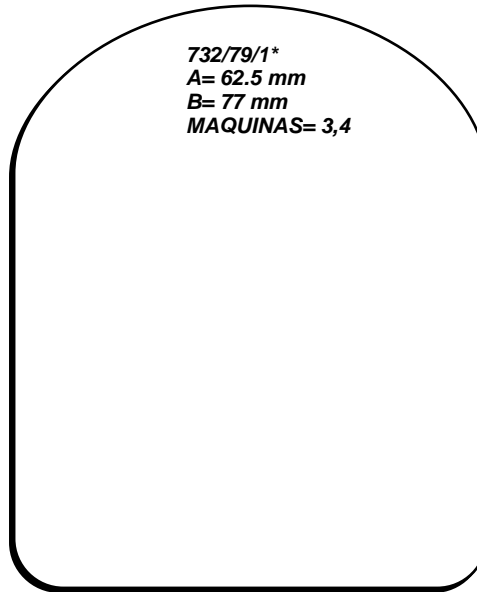
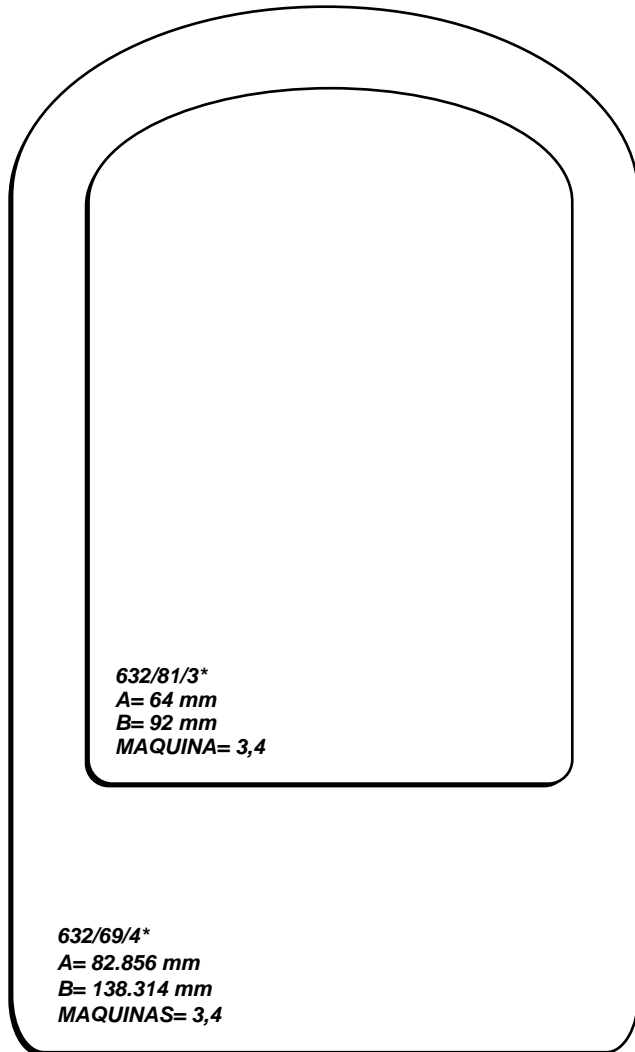

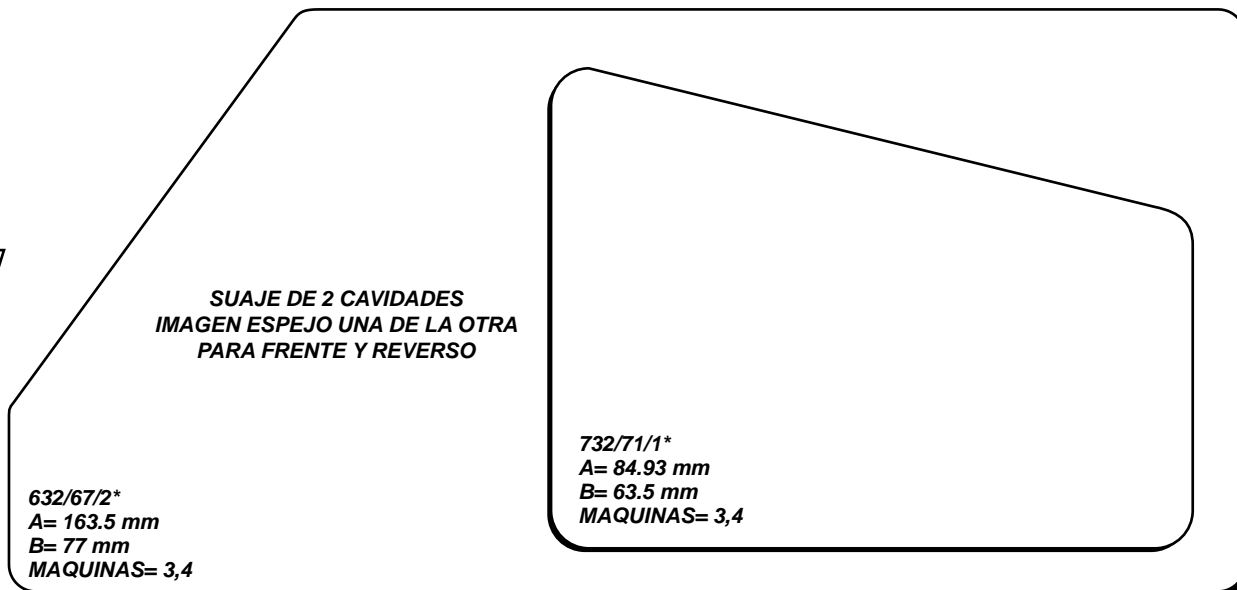
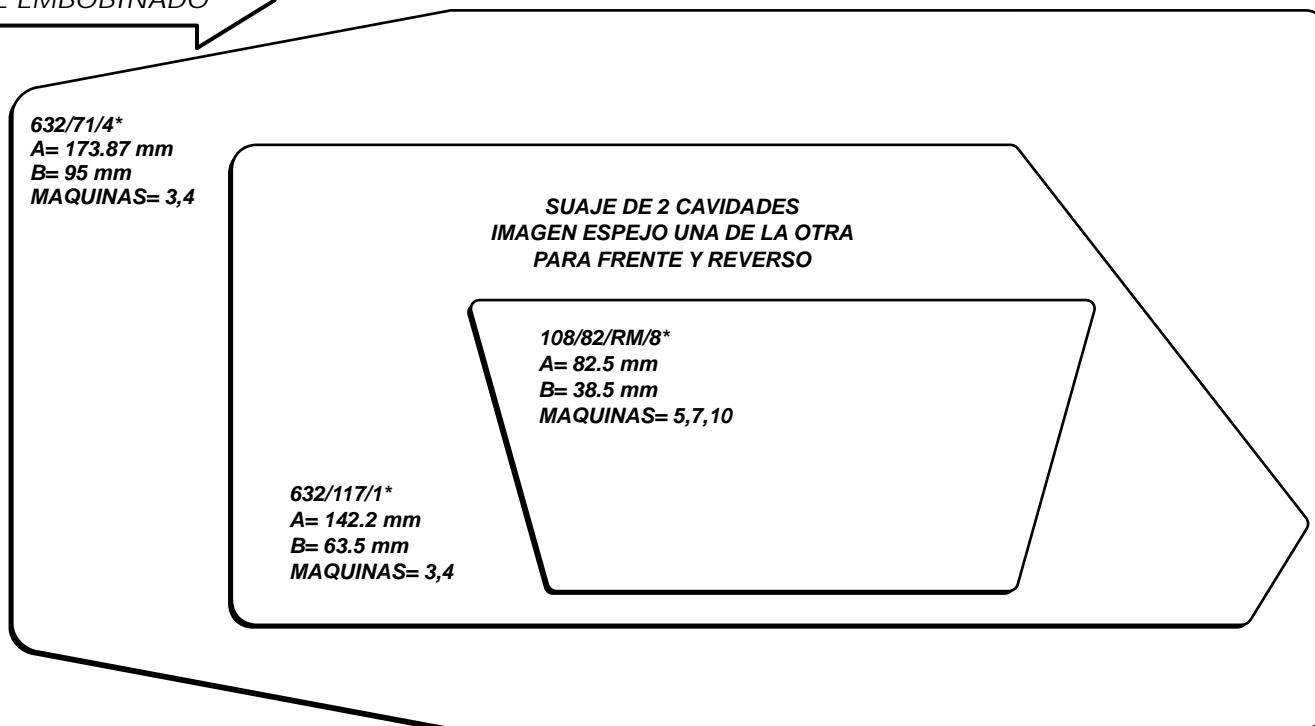
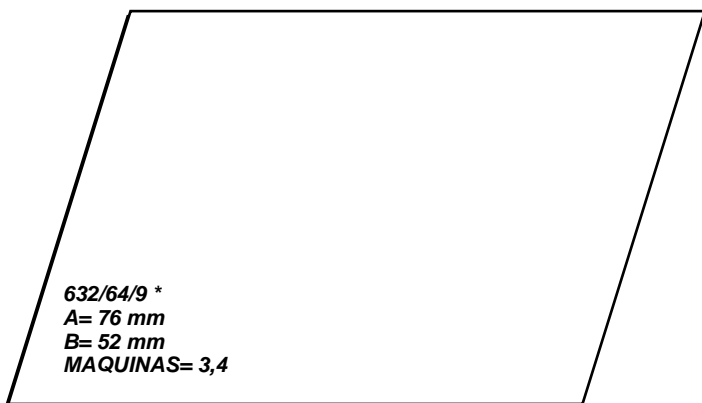
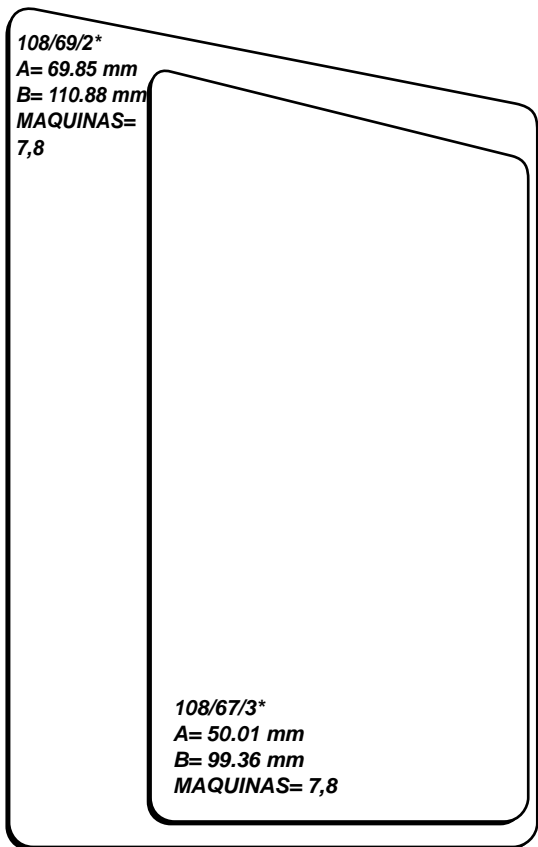

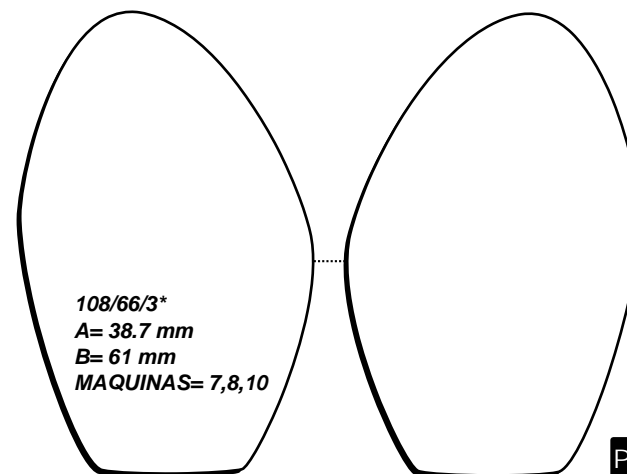
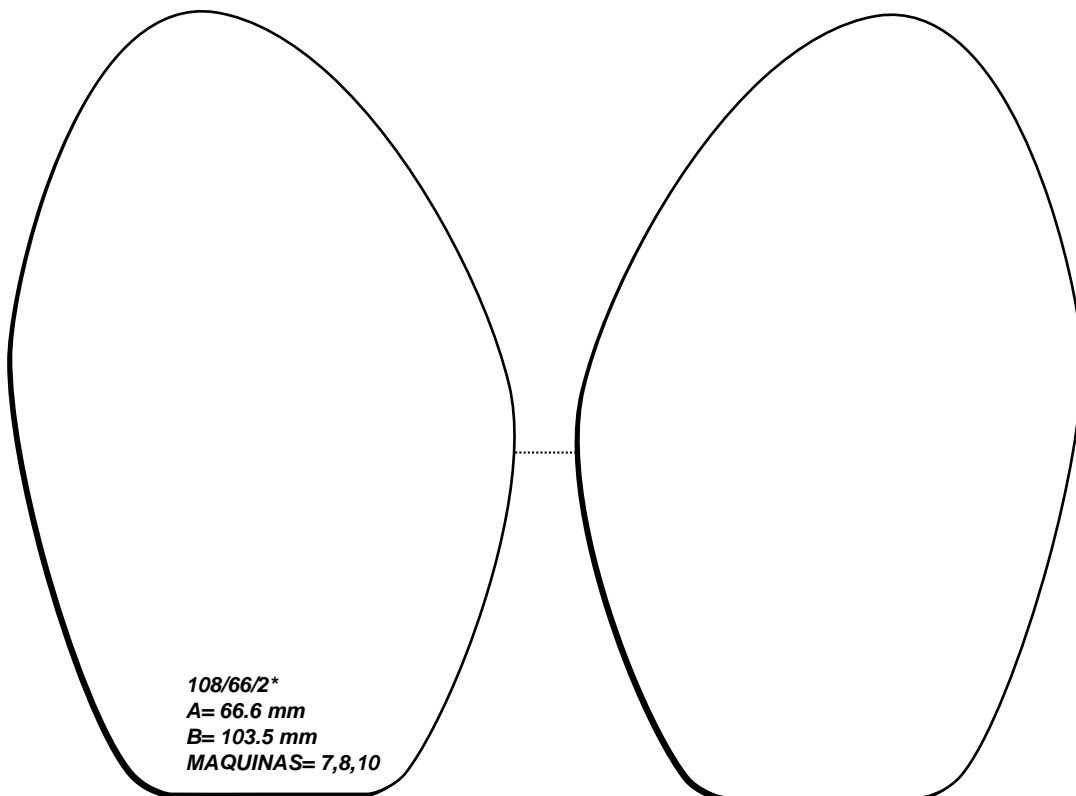
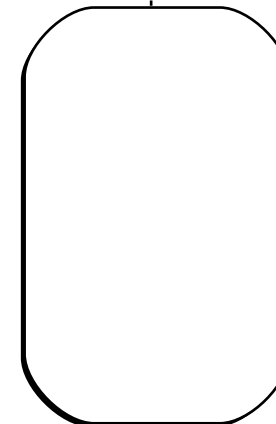
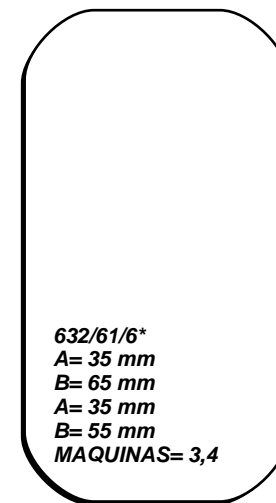
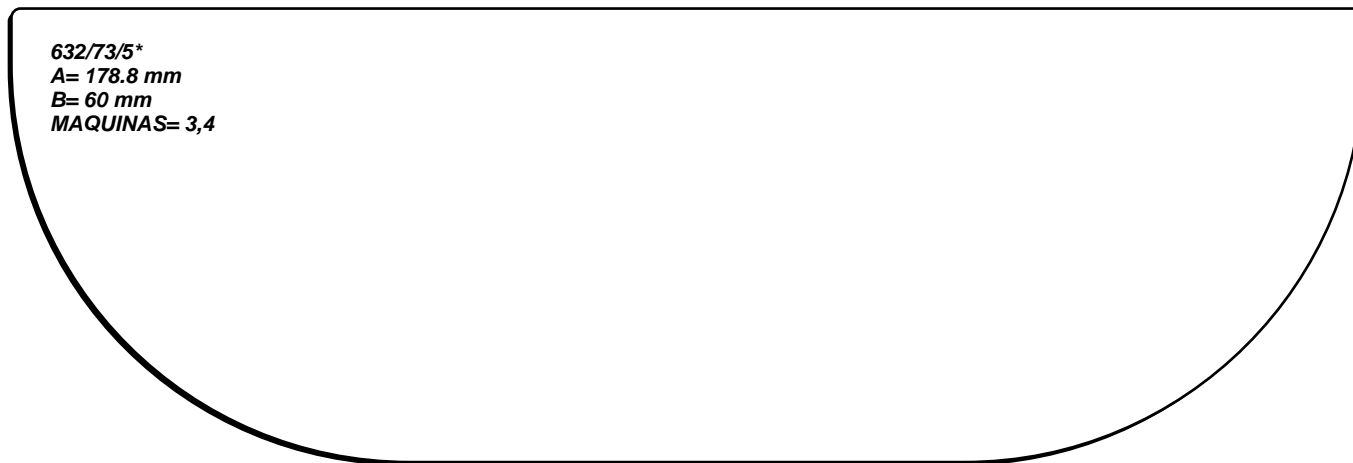

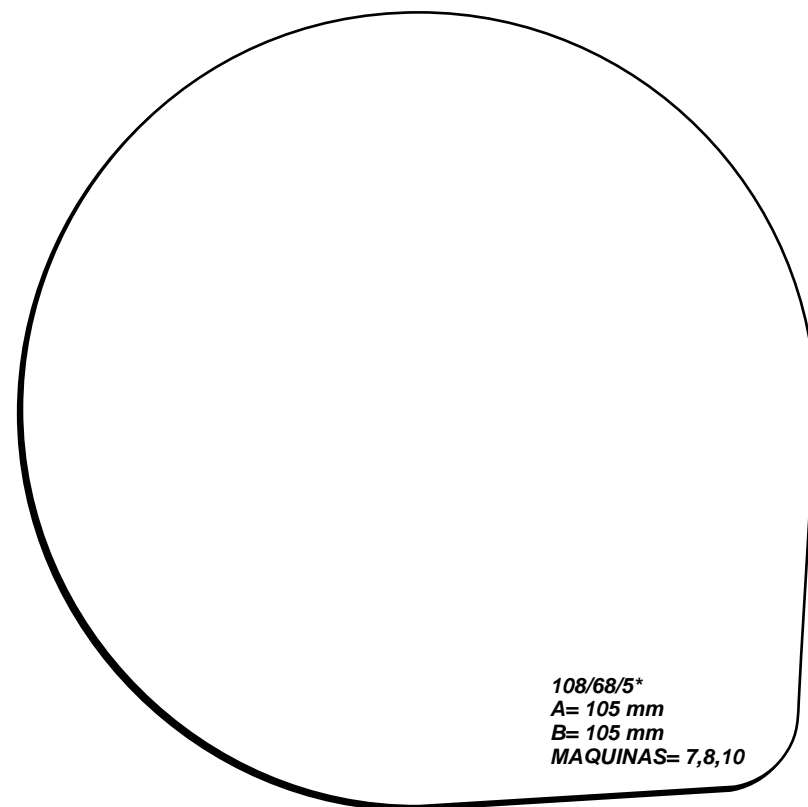
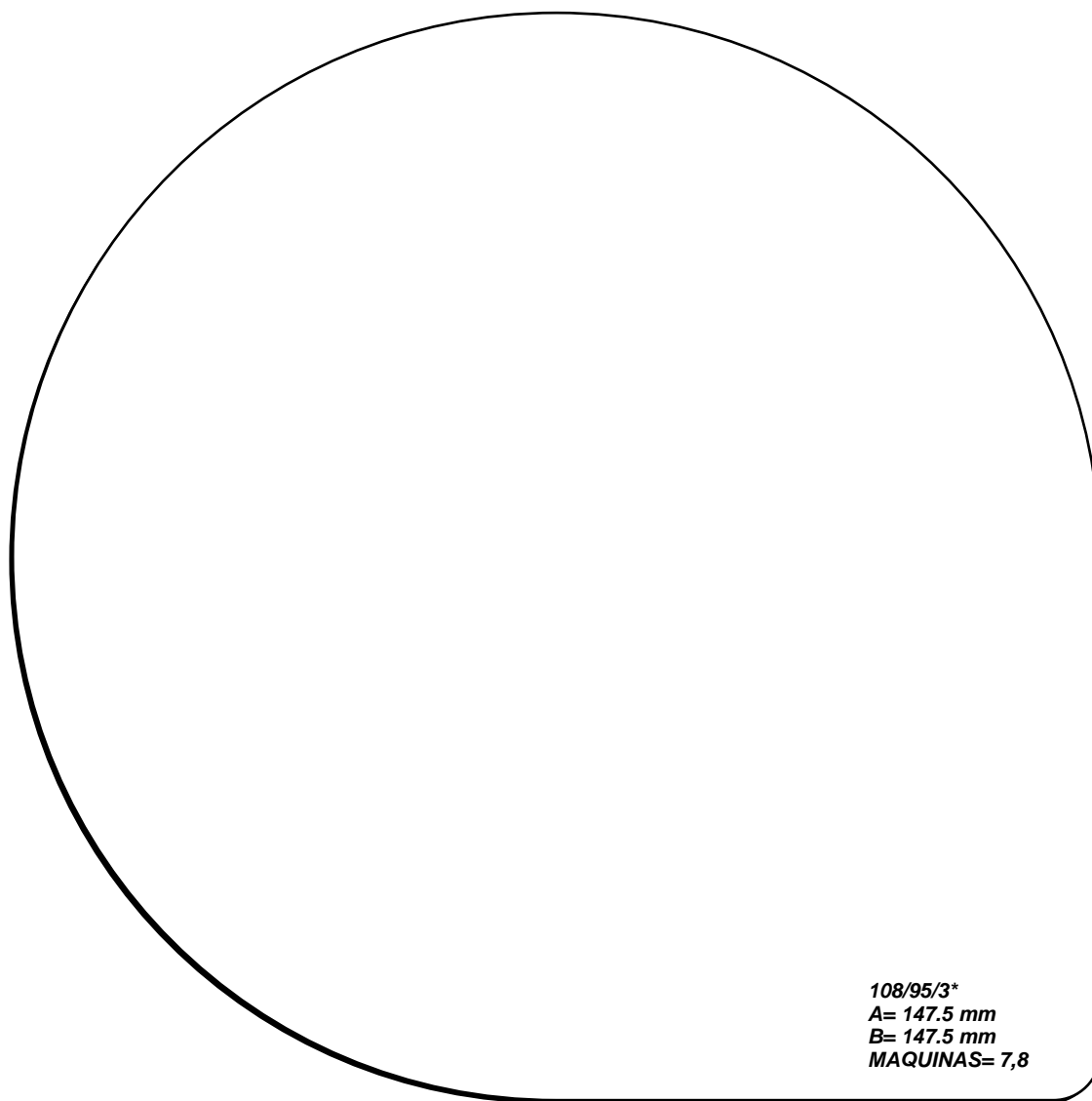

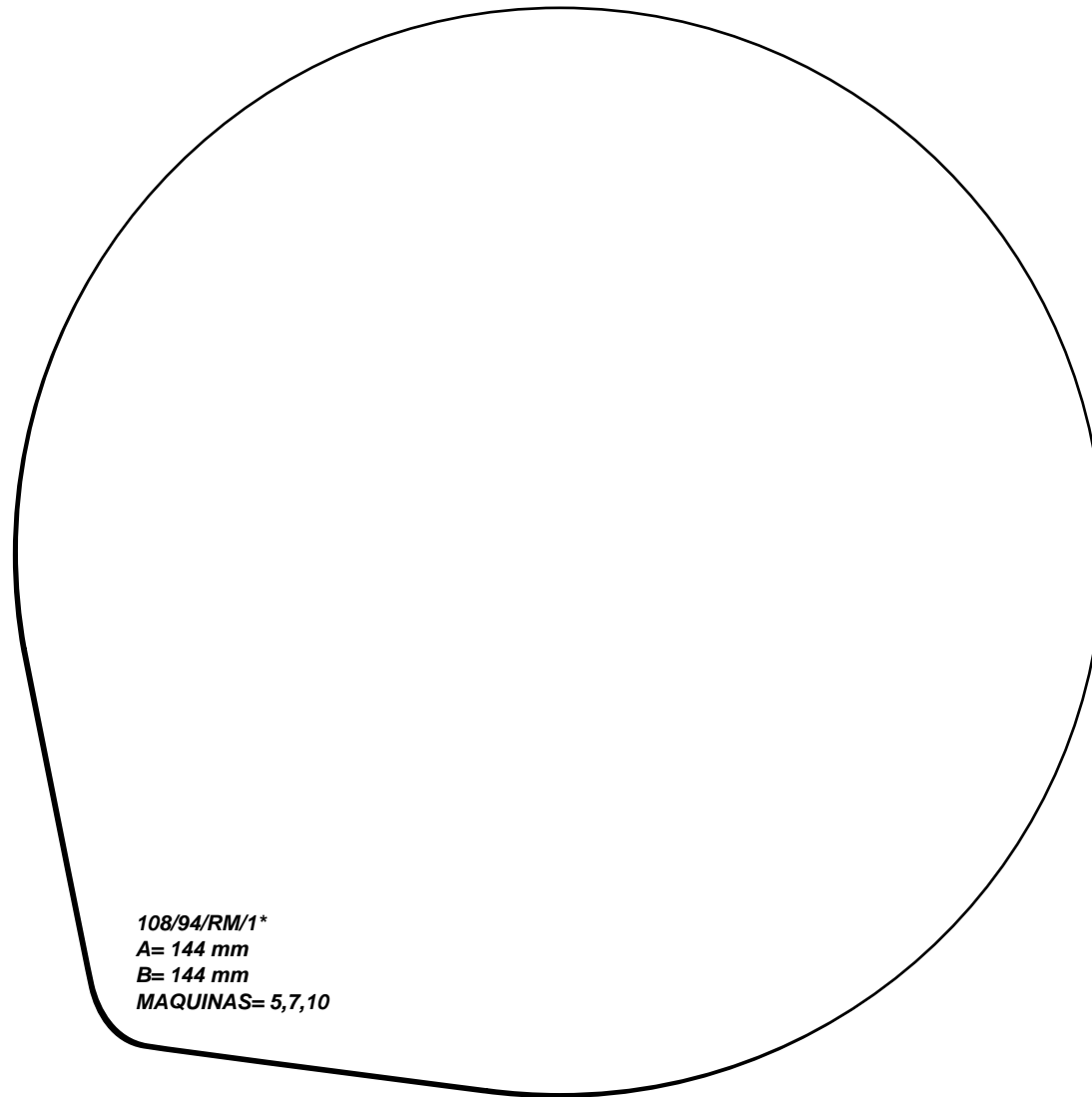

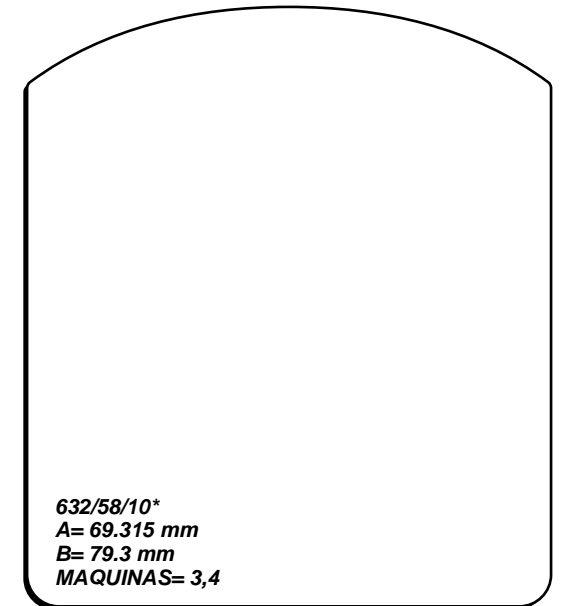
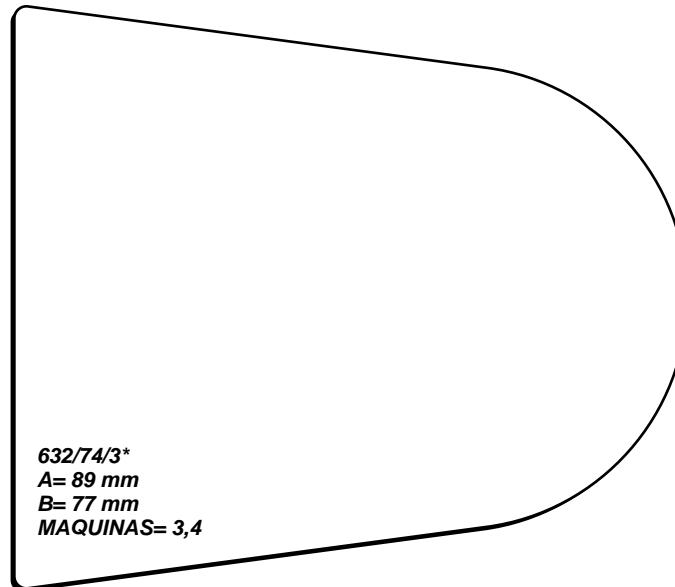
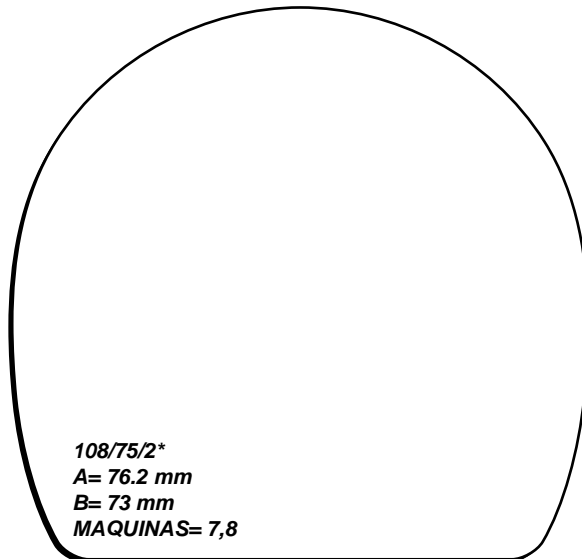
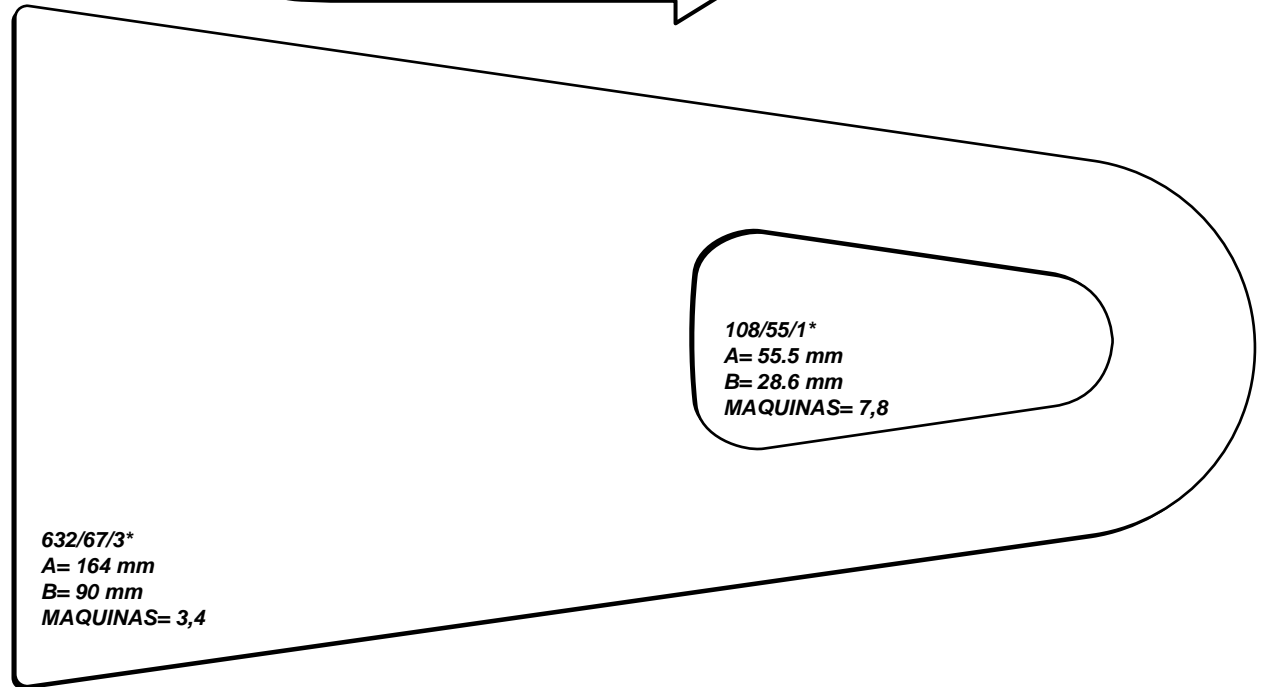
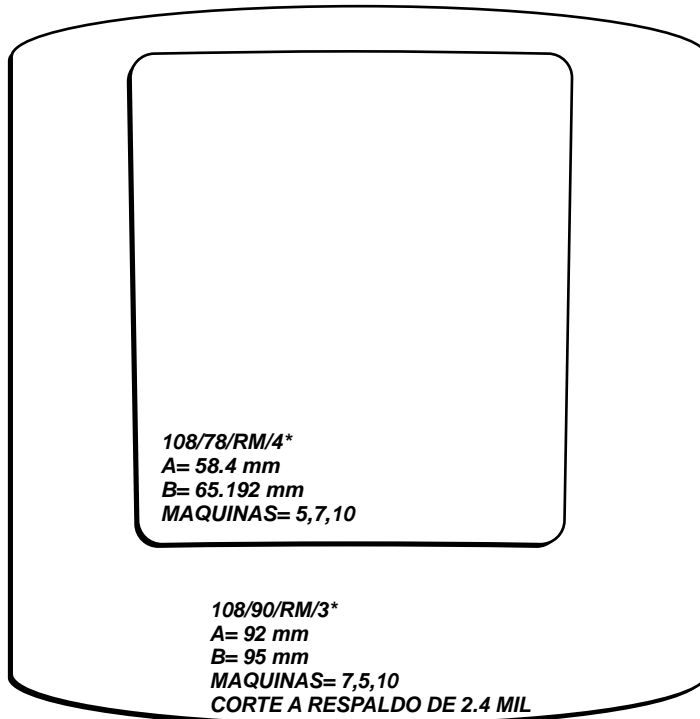

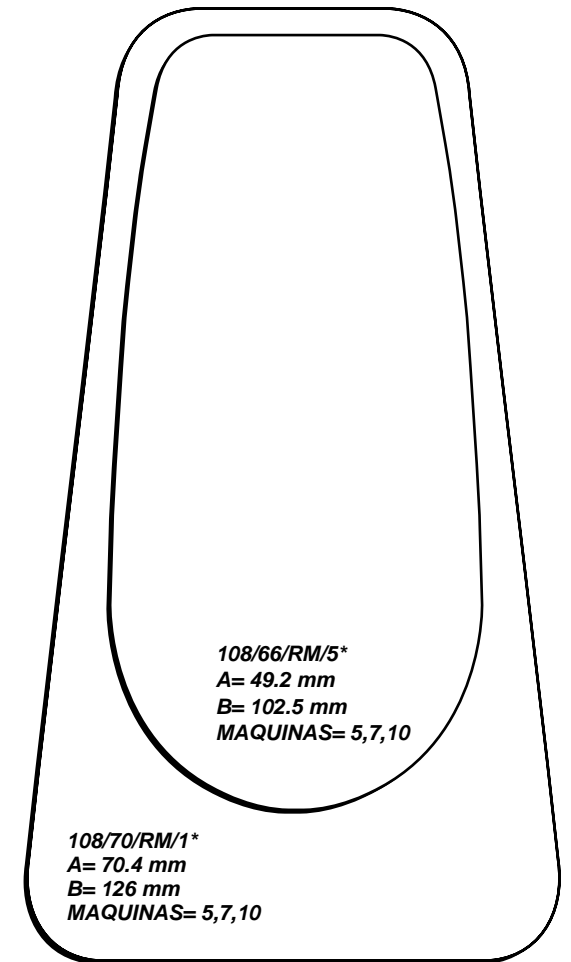
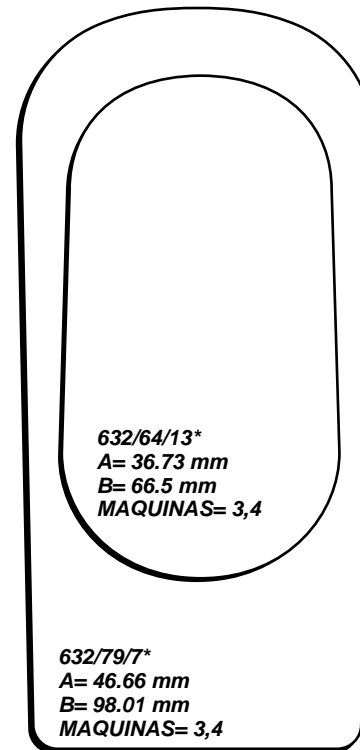
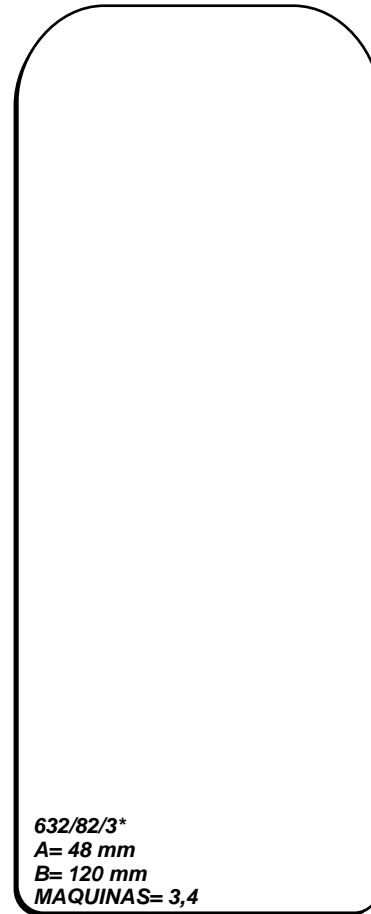
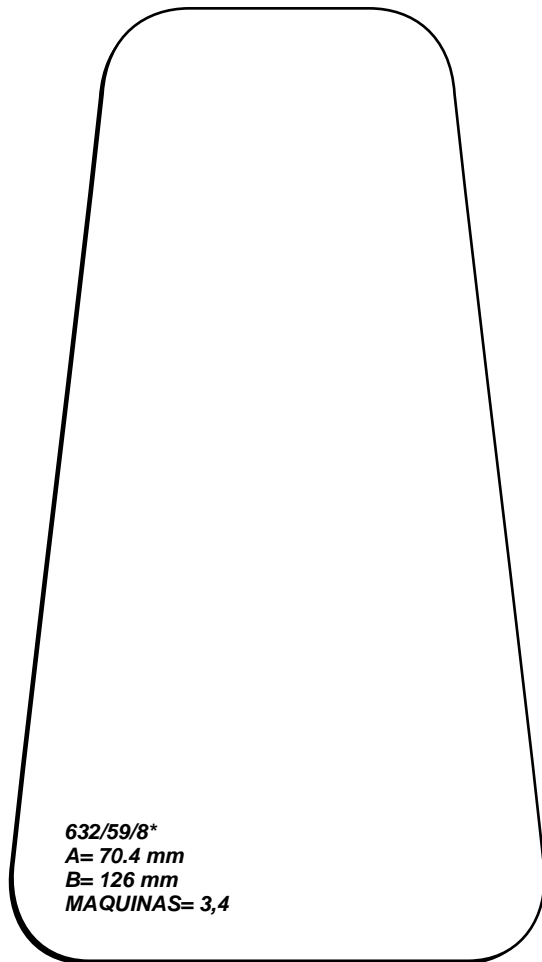

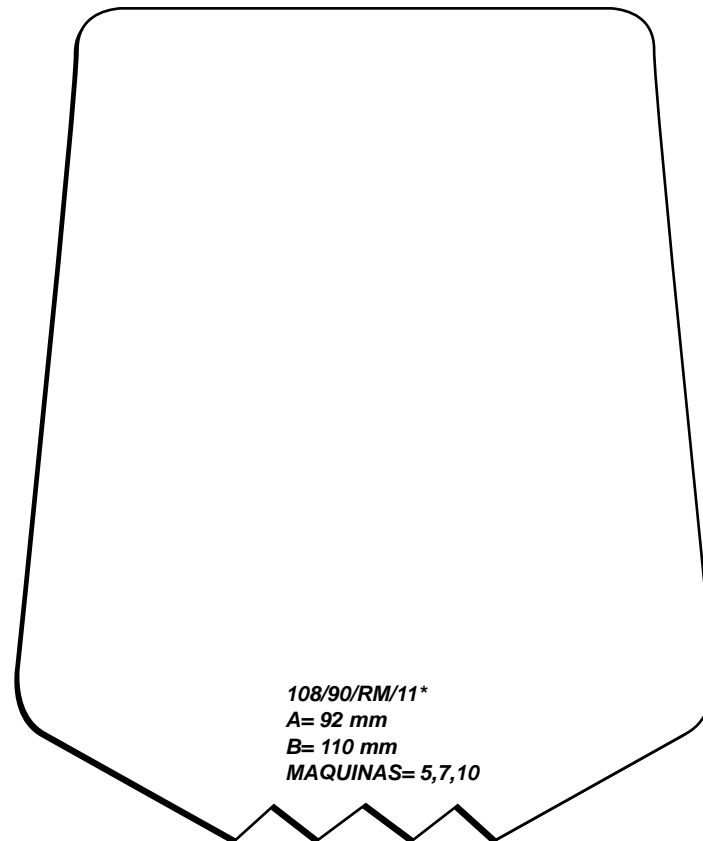
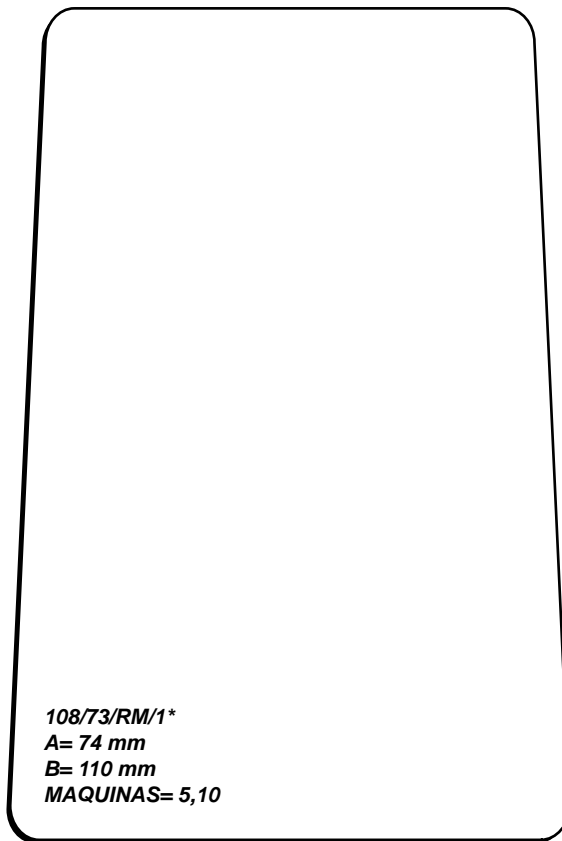

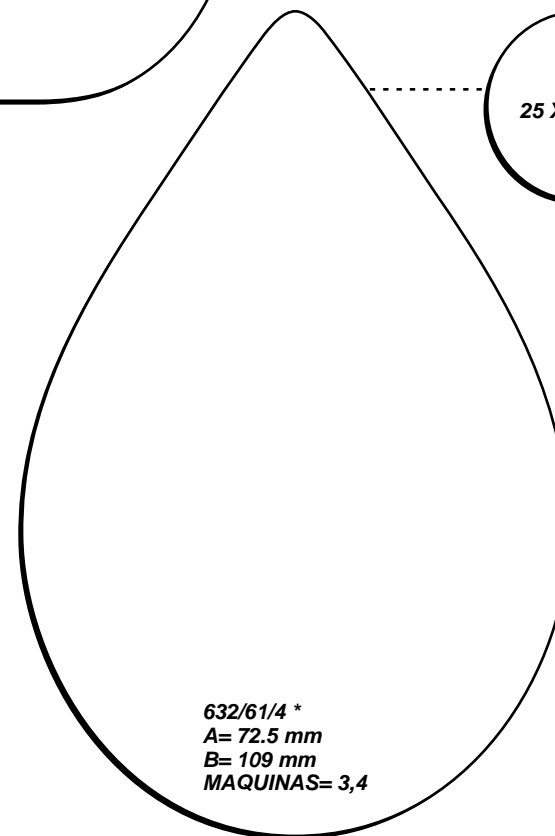
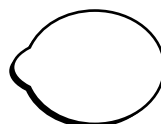
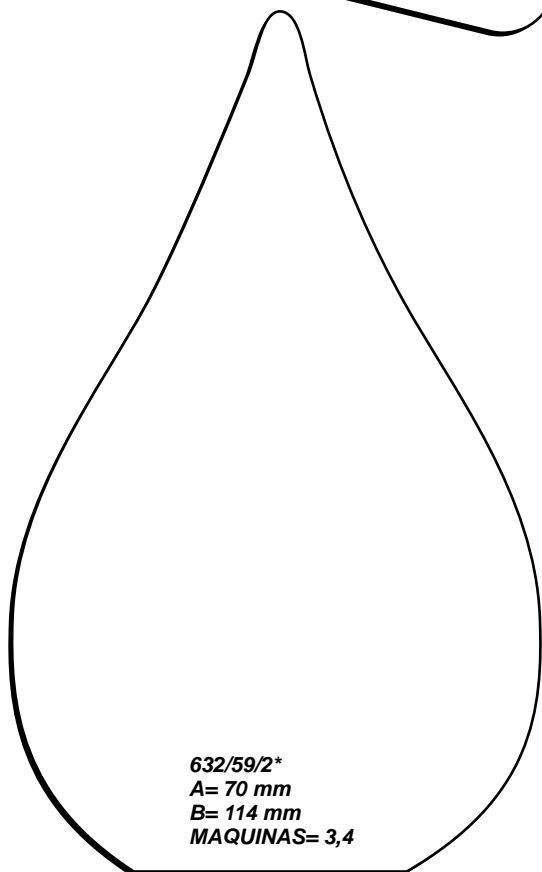
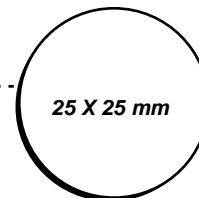
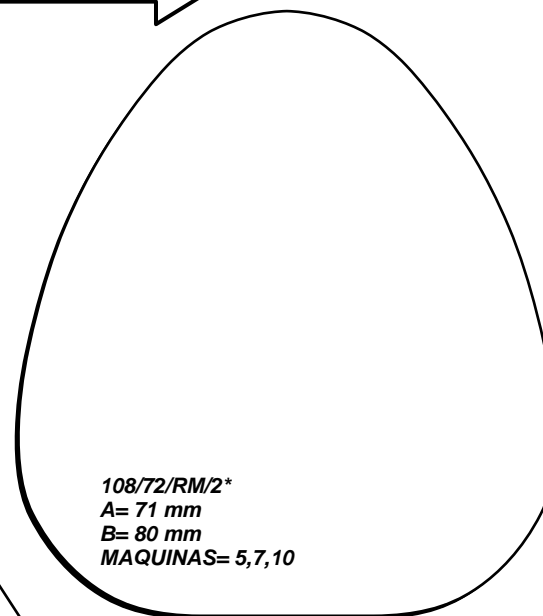
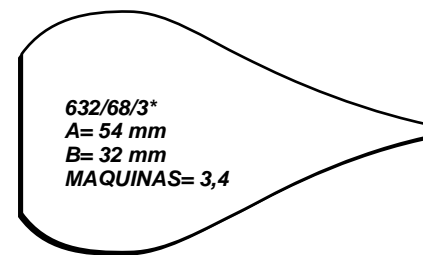
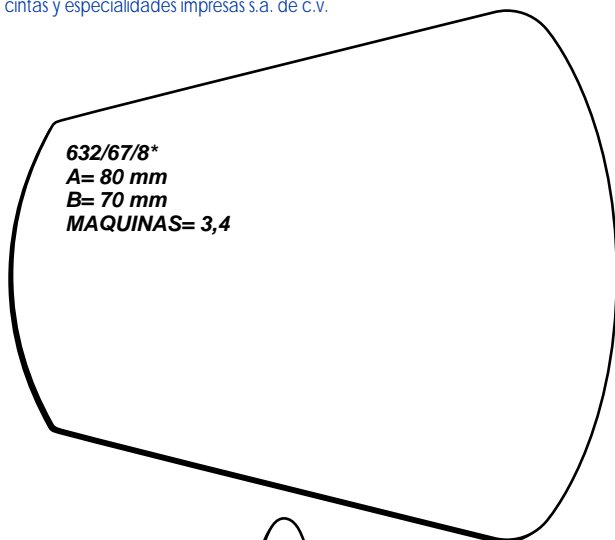



108/76/RM//3*
A= 237.5 mm
B= 24.078 mm
MAQUINAS= 5,10

108/78/3*
A= 120.7 mm
B= 73 mm
MAQUINAS= 7,8,10

632/60/4*
A= 72.48 mm
B= 100.49 mm
MAQUINAS= 3,4

108/53/2*
A= 32 mm
B= 141.8 mm
MAQUINAS= 7,8

108/68/3*
A= 104.95 mm
B= 71.77 mm
MAQUINAS= 7,8,10

632/94/1*
A= 114.20 mm
B= 46.43 mm
MAQUINAS= 3,4

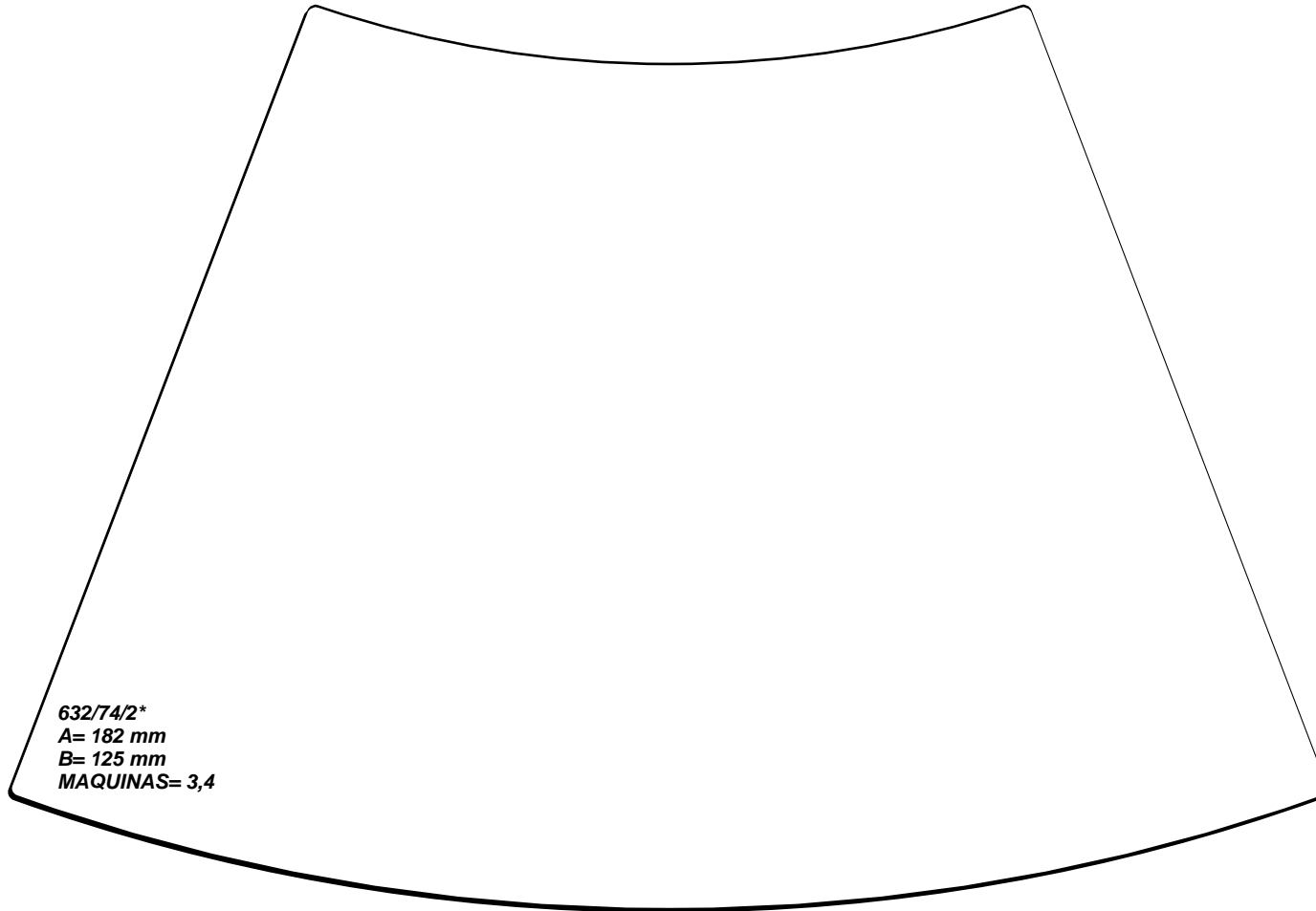
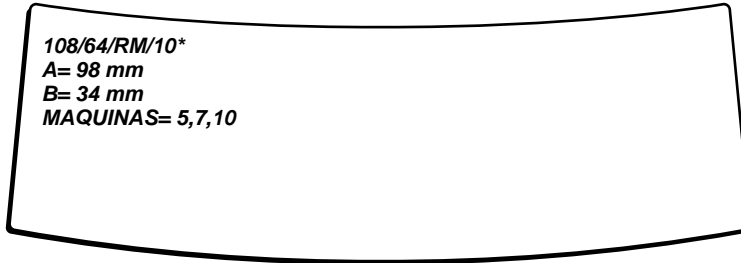

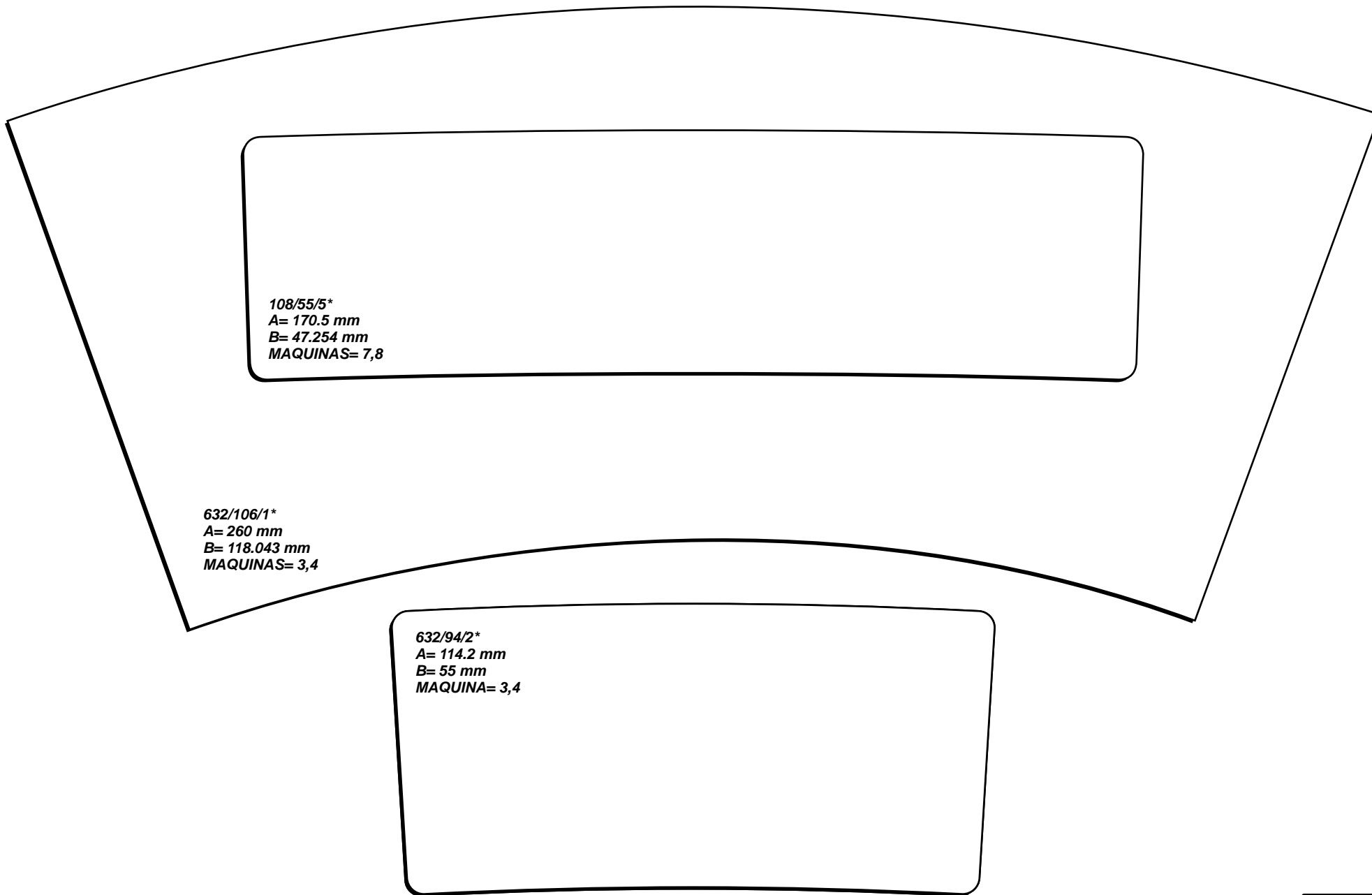



108/104/1*
A= 327 mm
B= 165 mm
MAQUINAS= 7,8,10

IMPRESO EN REDUCCION AL 75%

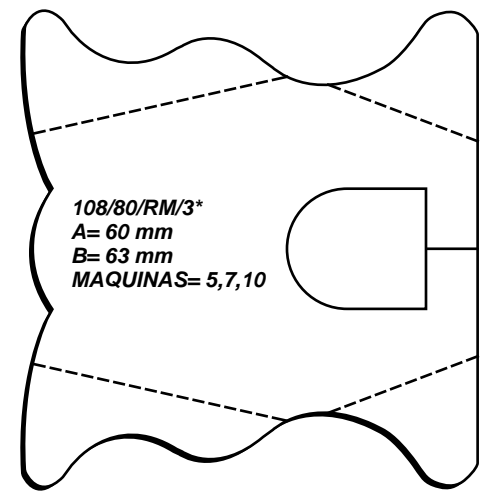
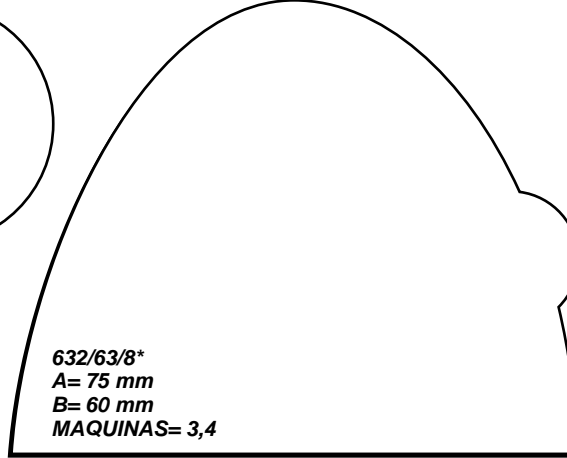
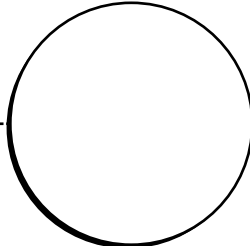
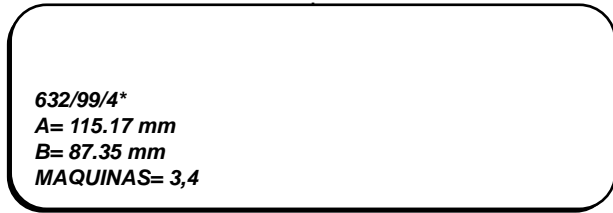
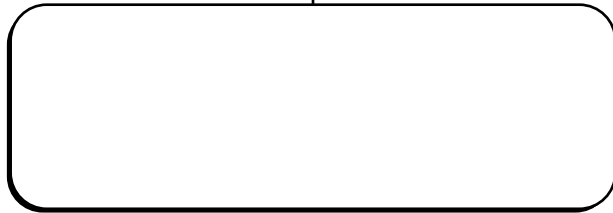
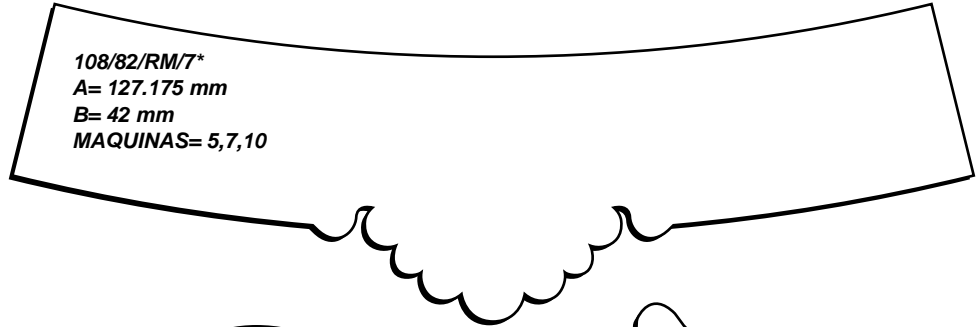
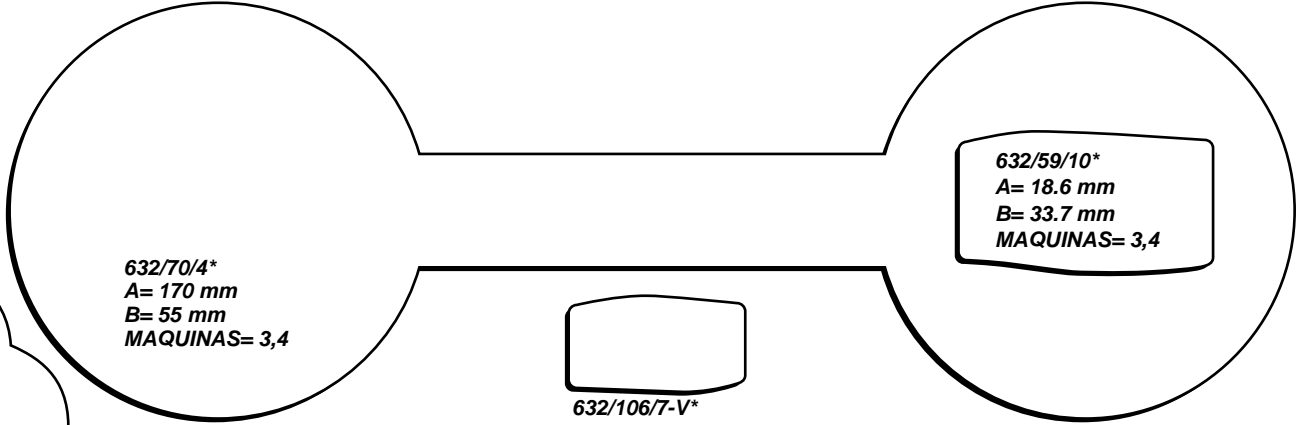
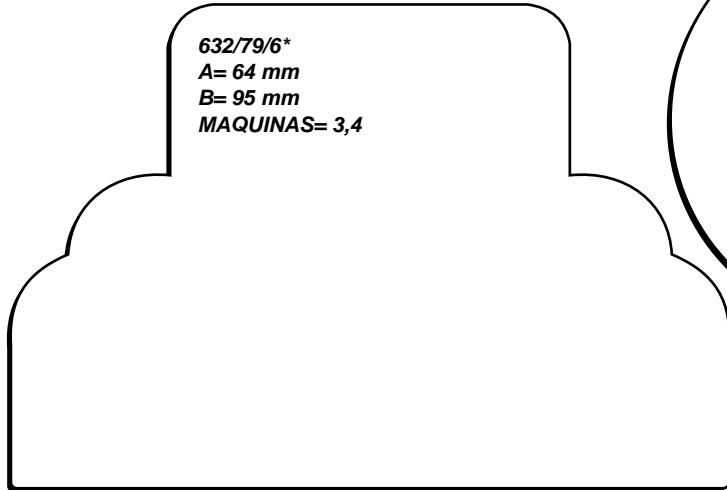

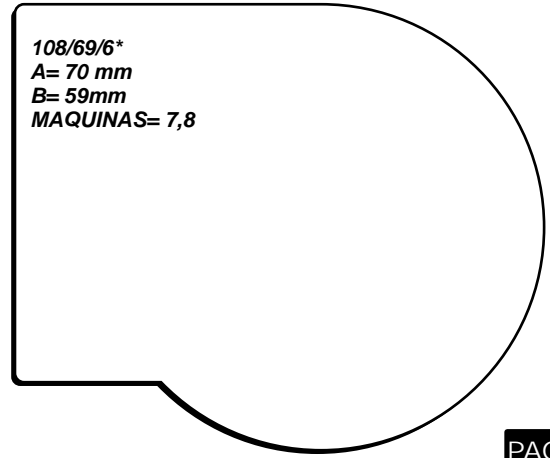
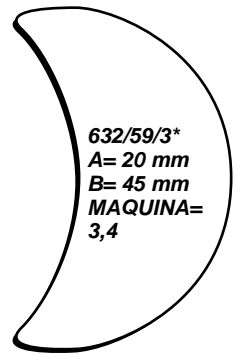
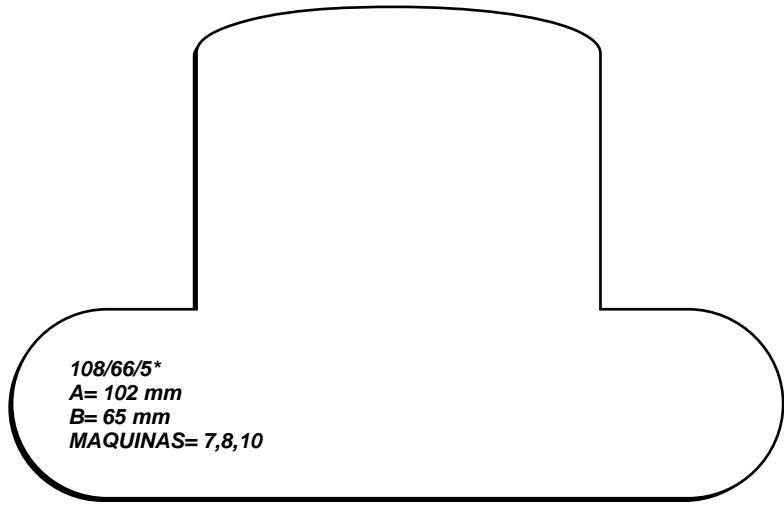
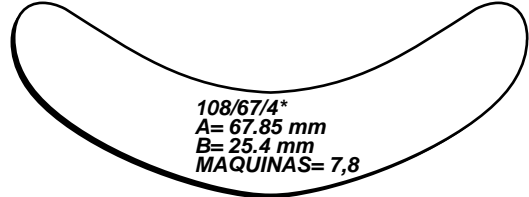
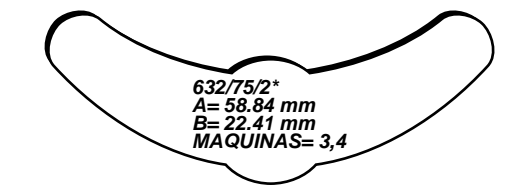
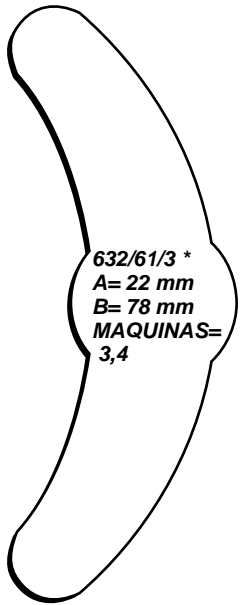
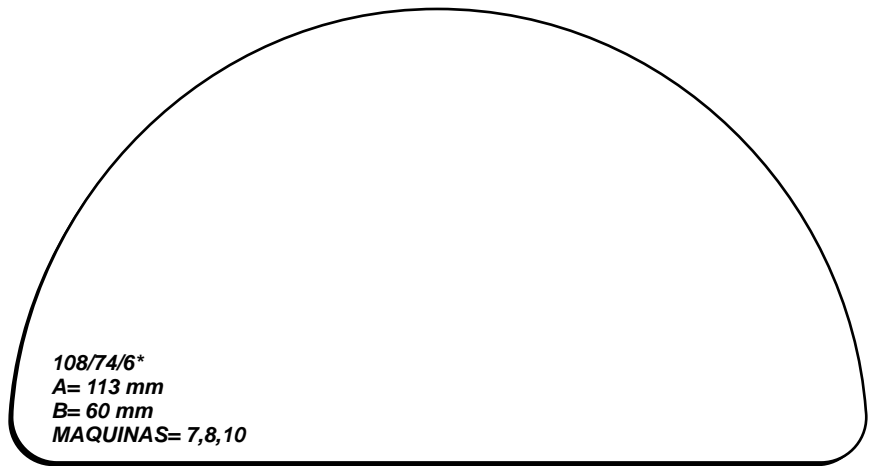
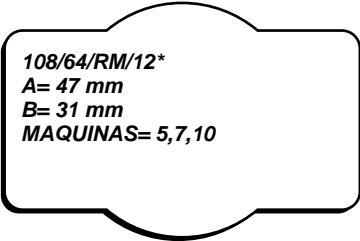
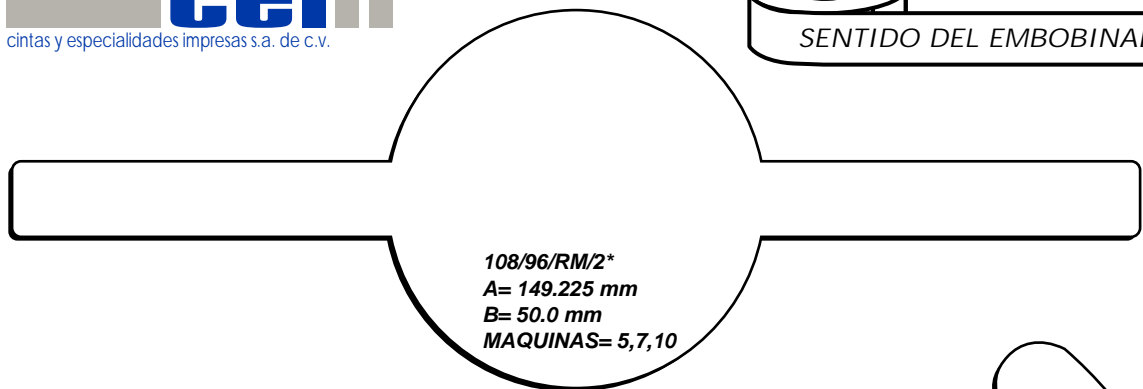



108/90/3*
A= 139.7 mm
B= 71.8 mm
MAQUINAS= 7,8,10

632/61/7*
A= 149 mm
B= 127 mm
MAQUINAS= 3,4

108/77/2*
A= 241.3 mm
B= 64.29 mm
MAQUINAS= 7,8

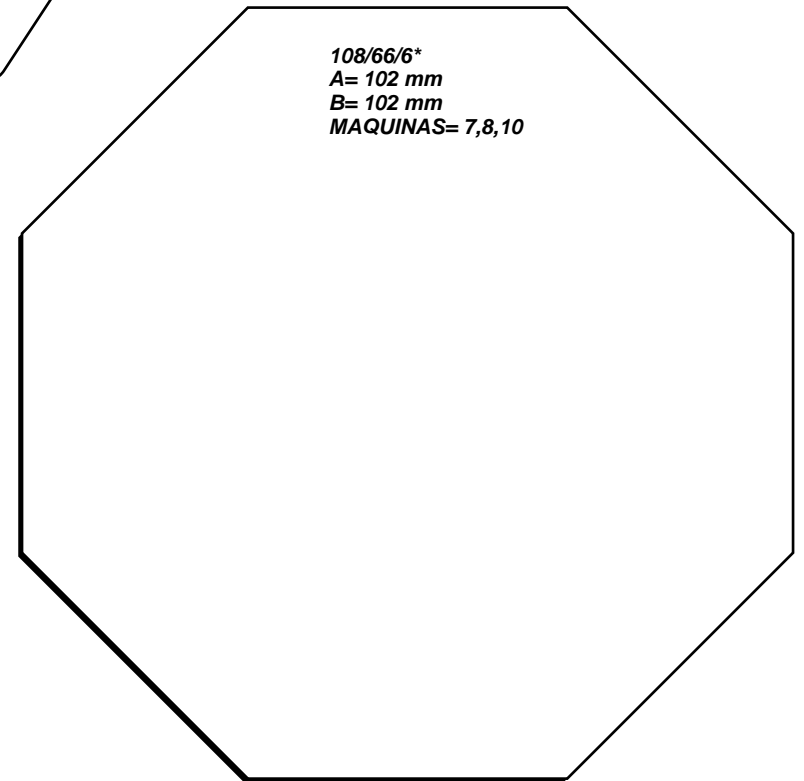
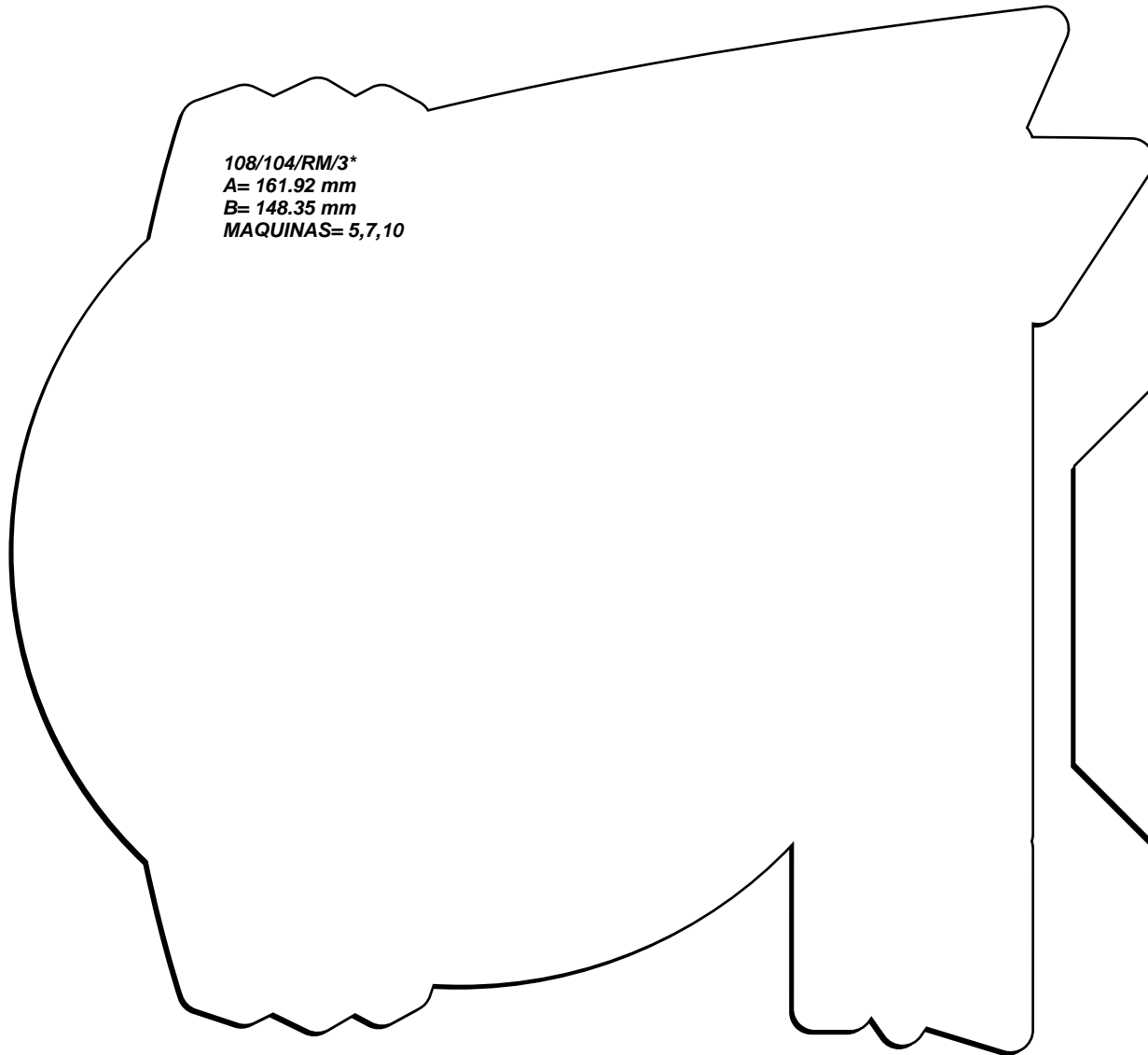

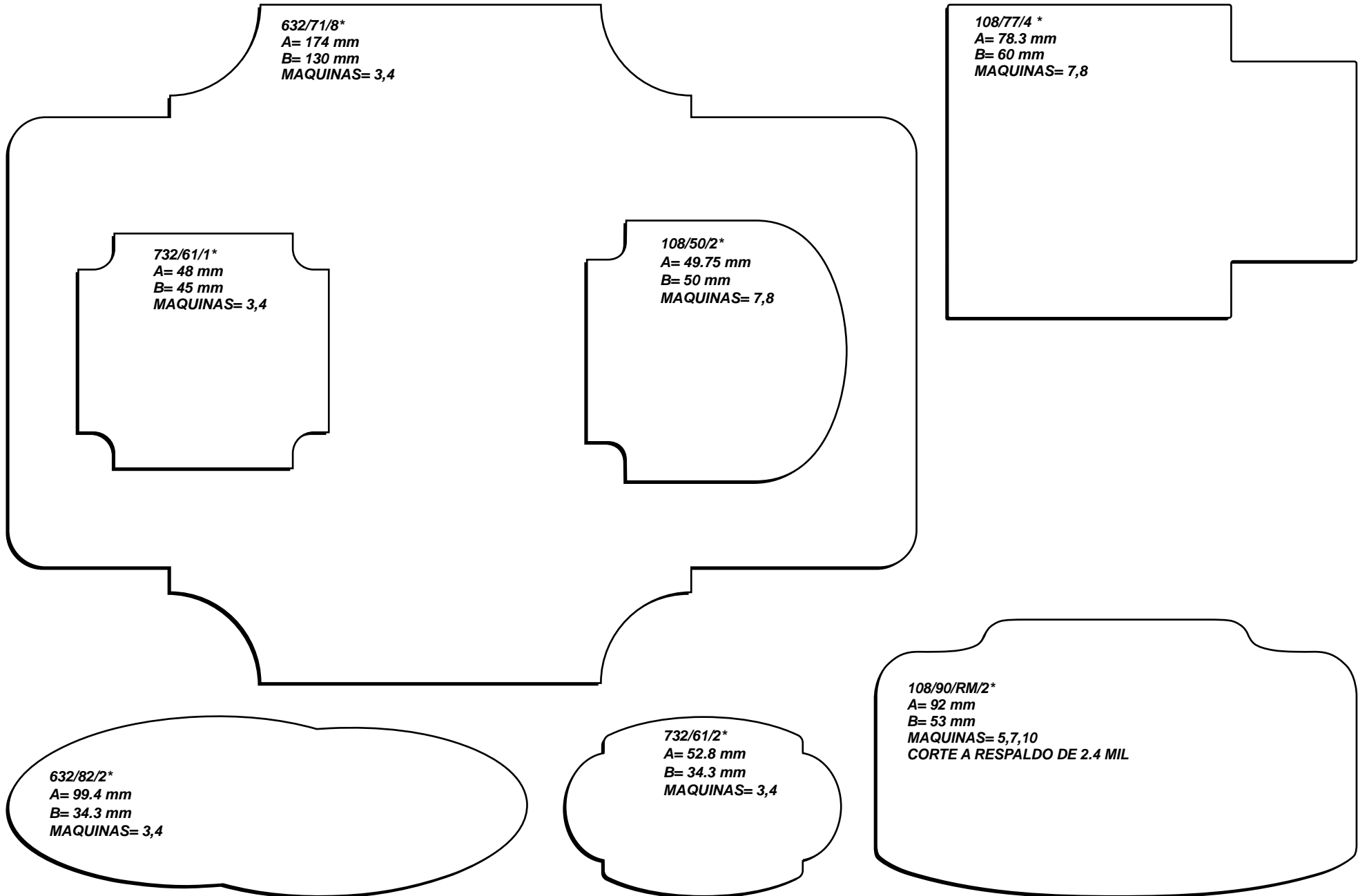

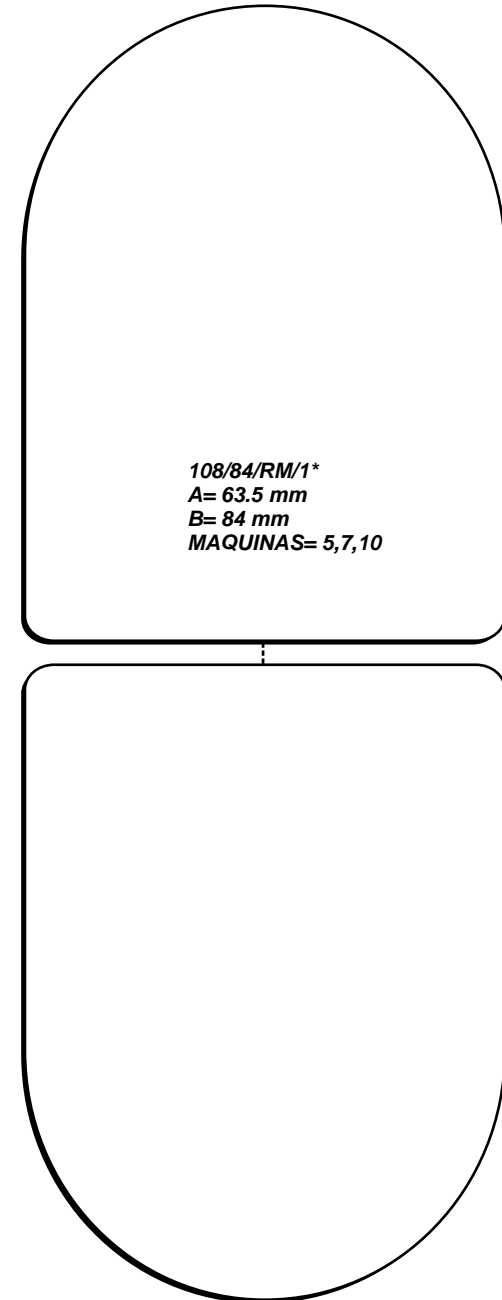
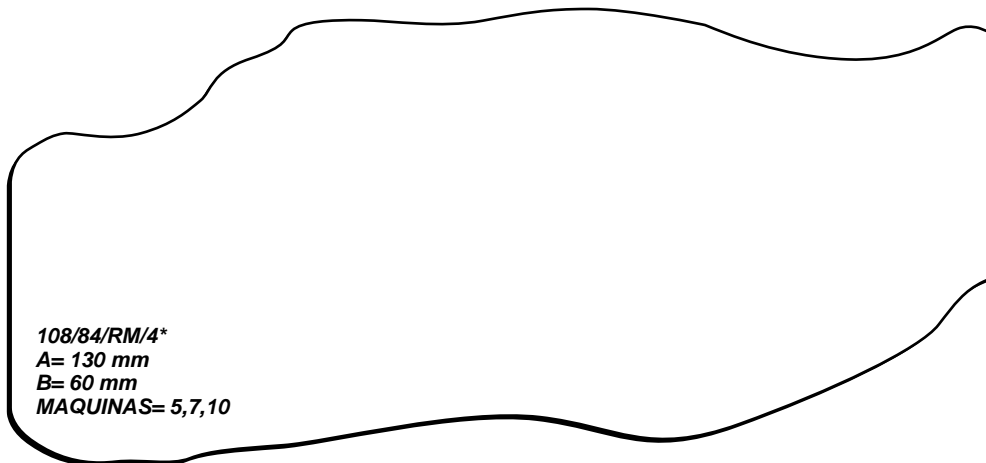
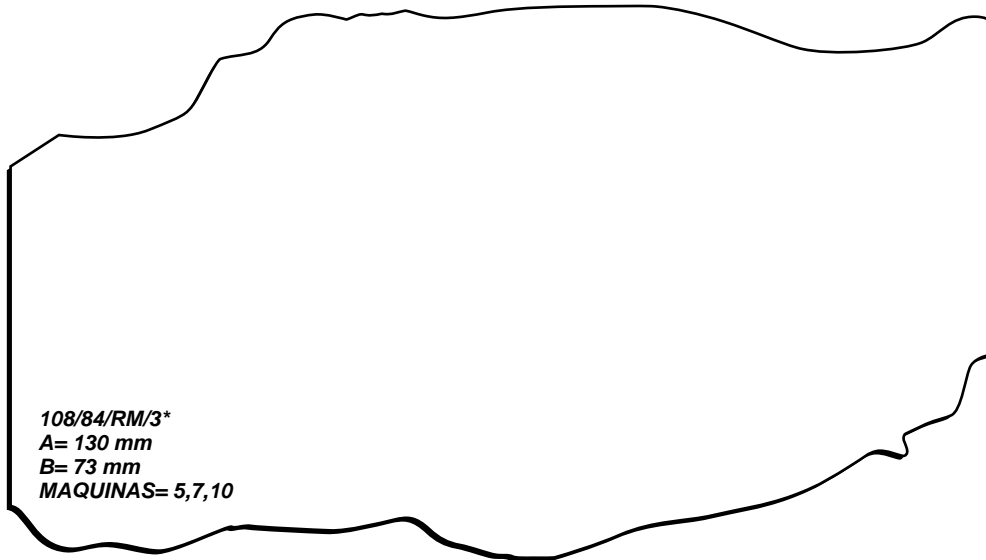

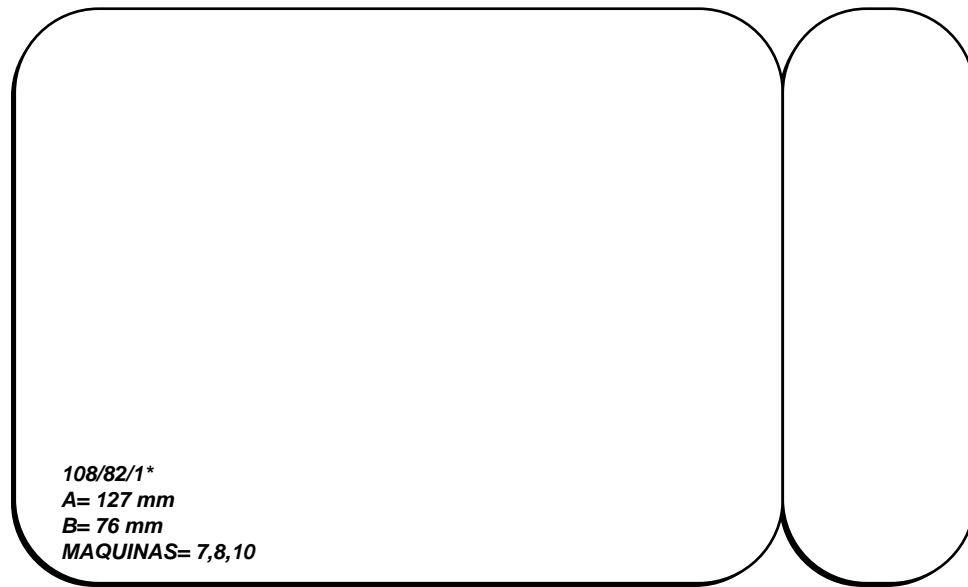
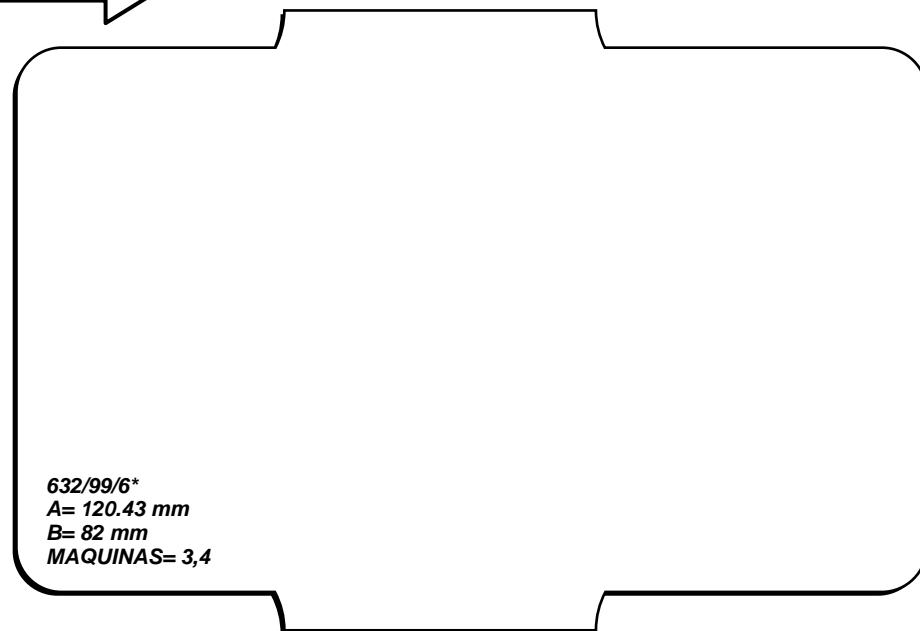
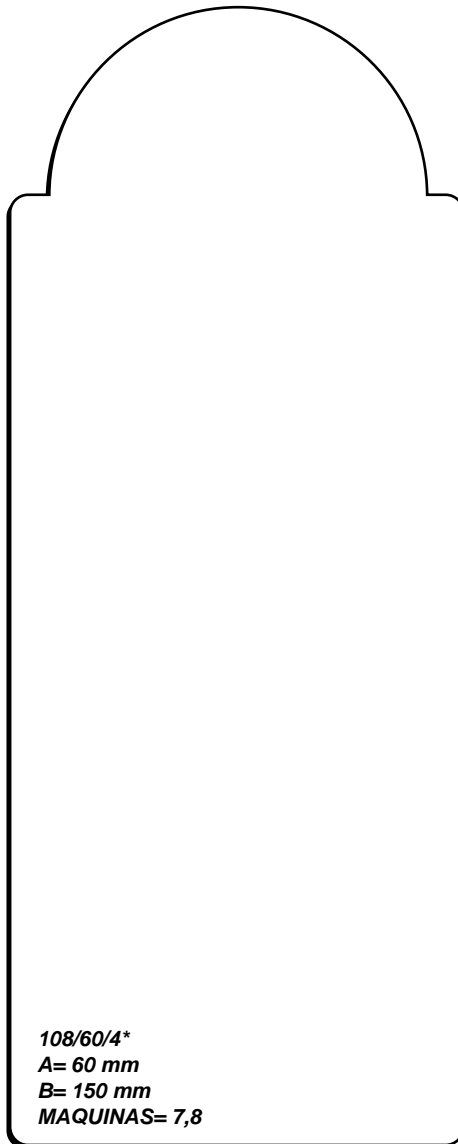
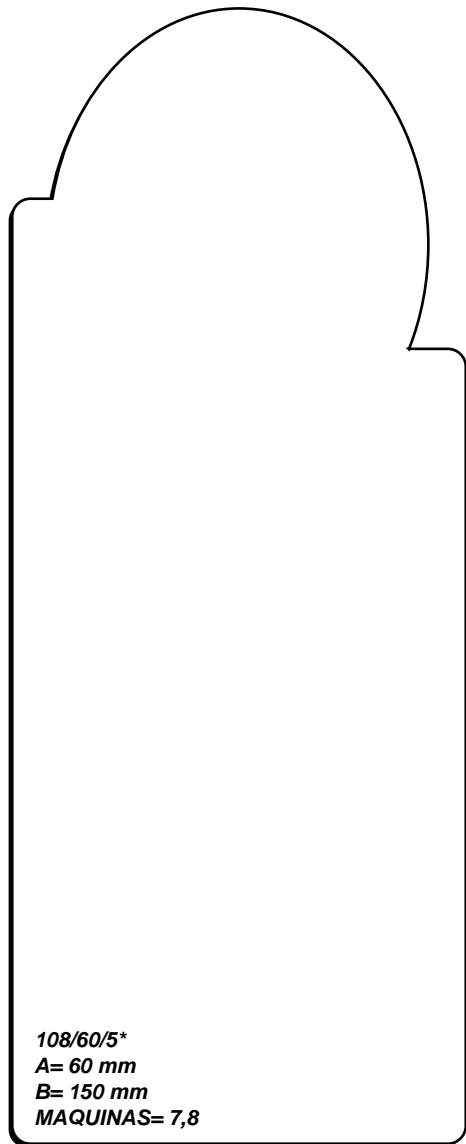

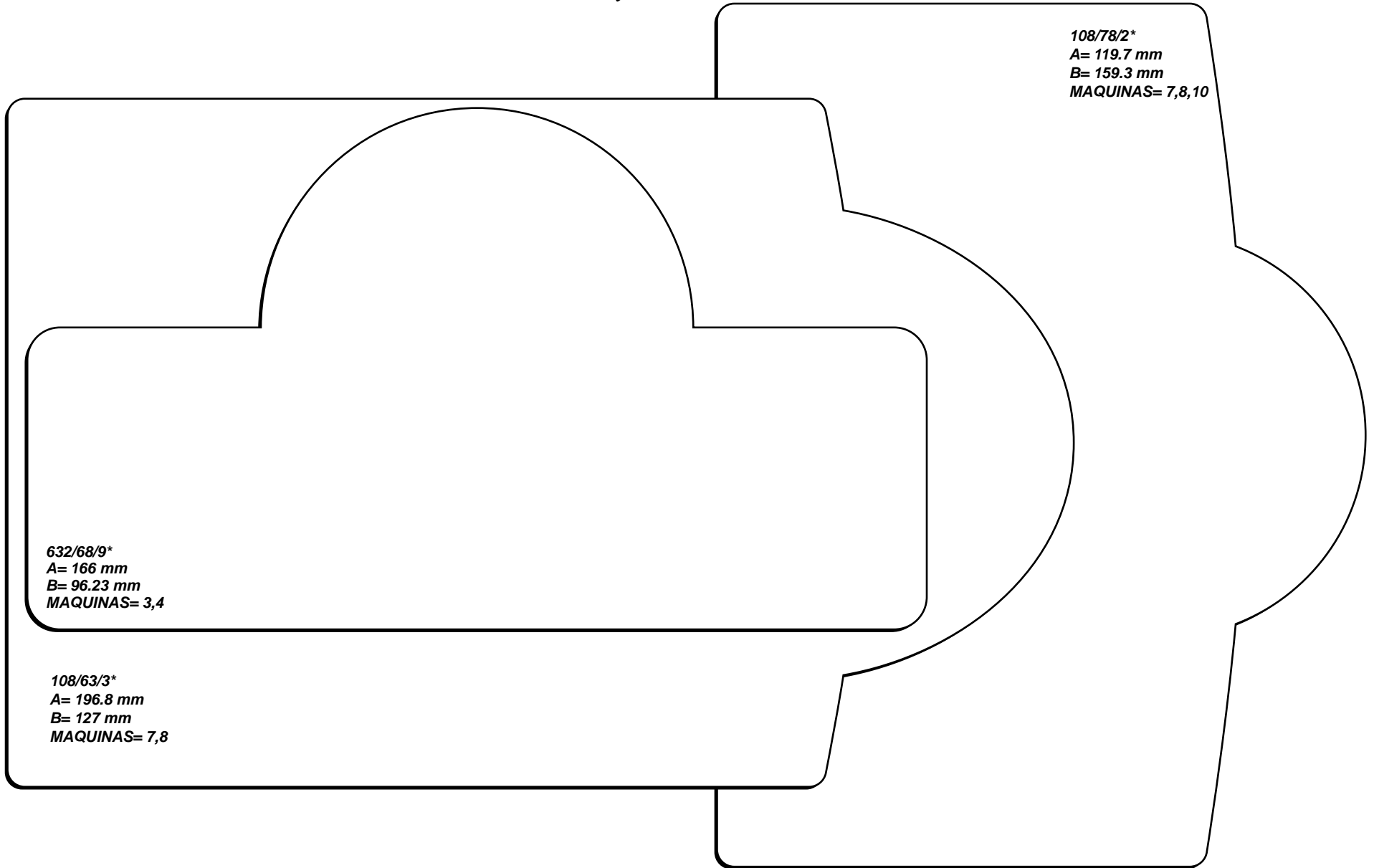

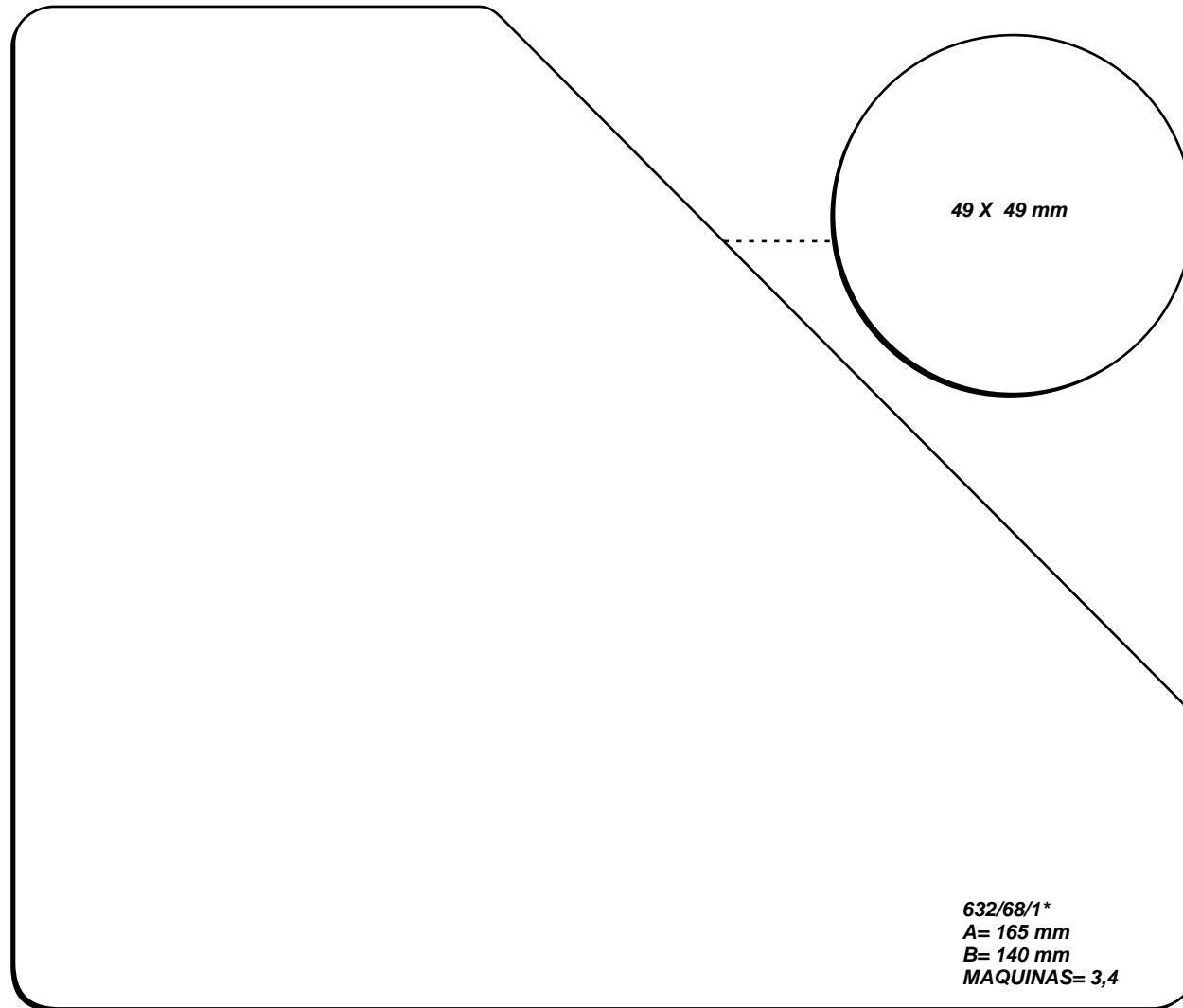

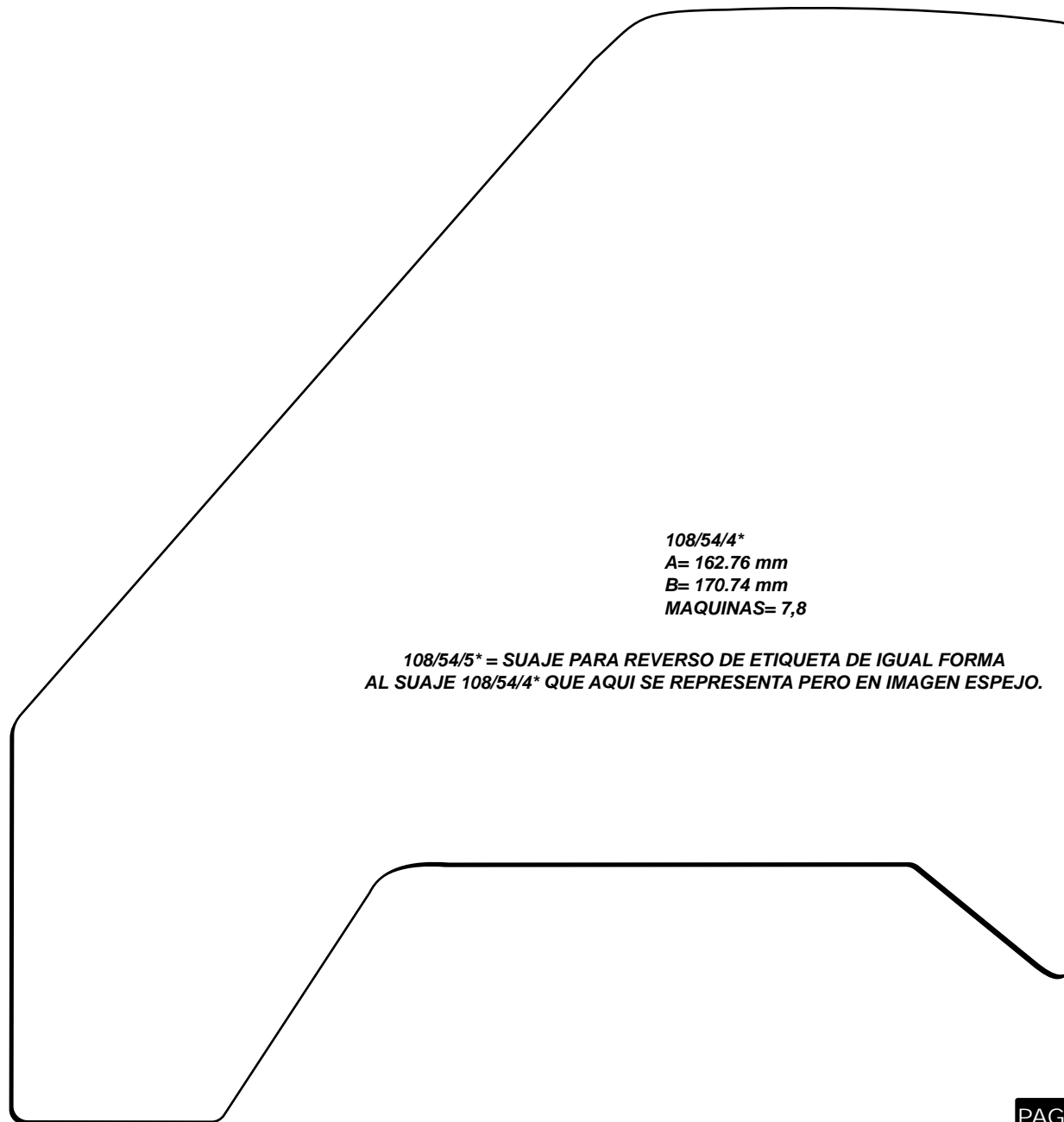
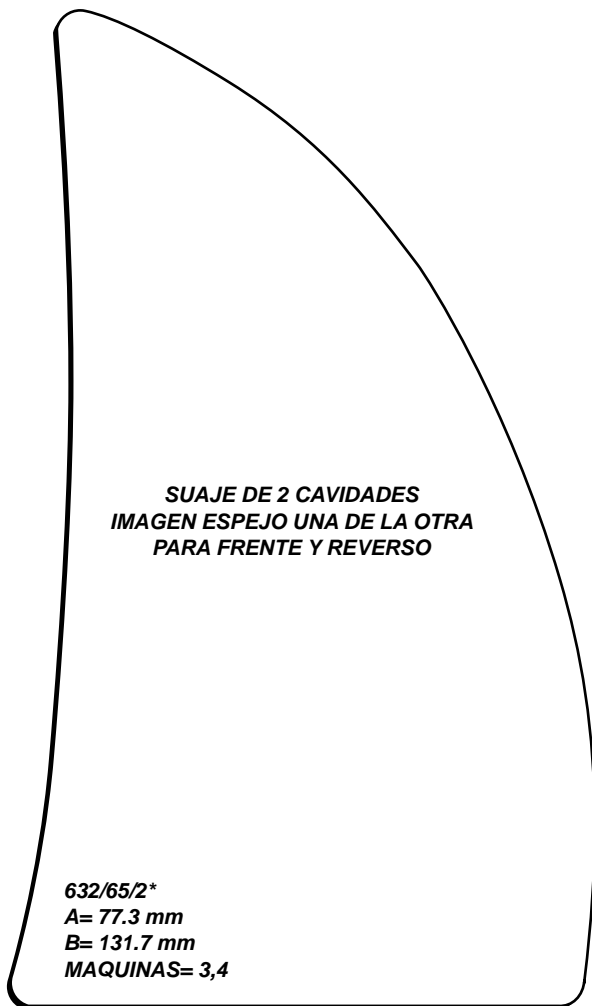

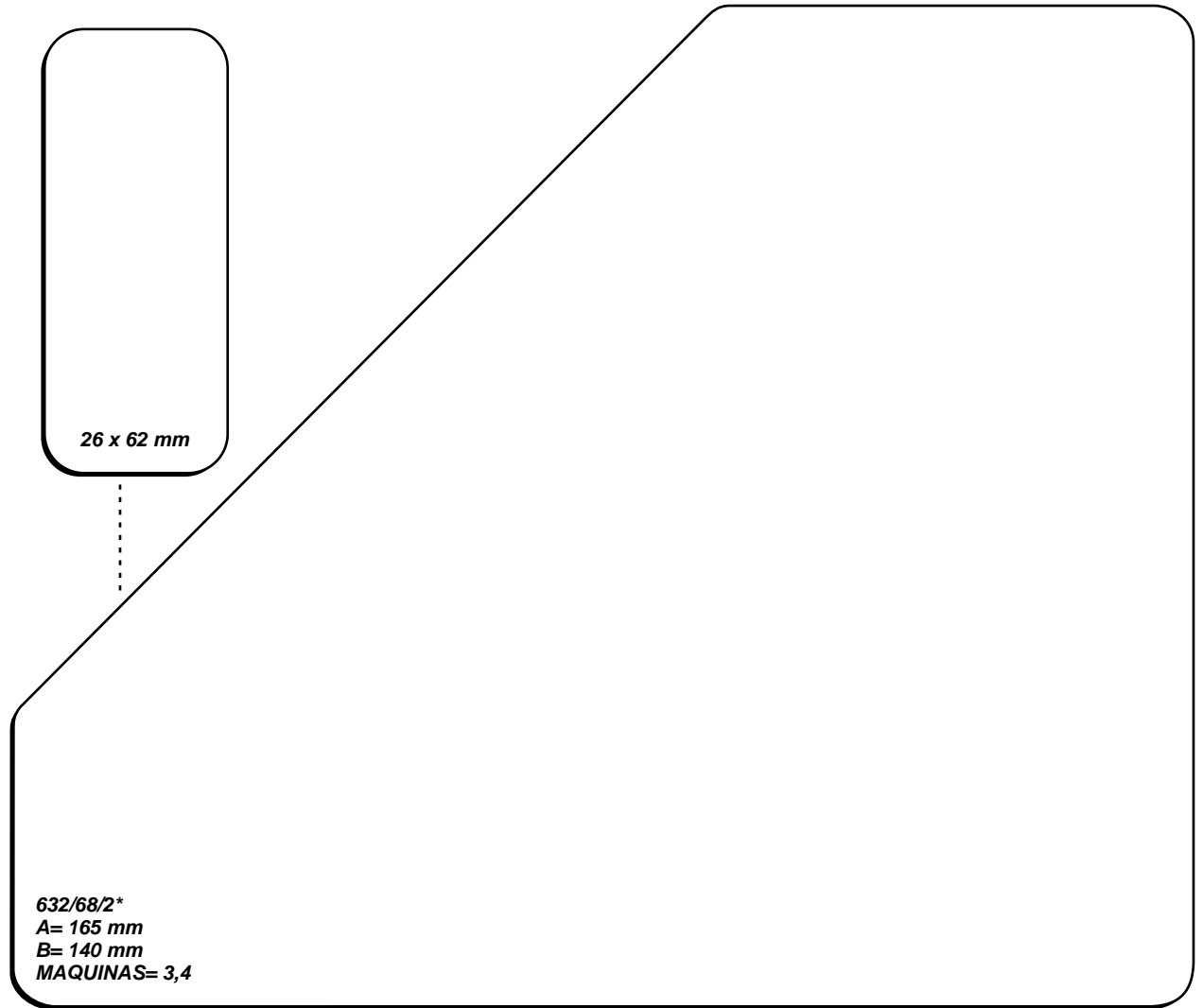
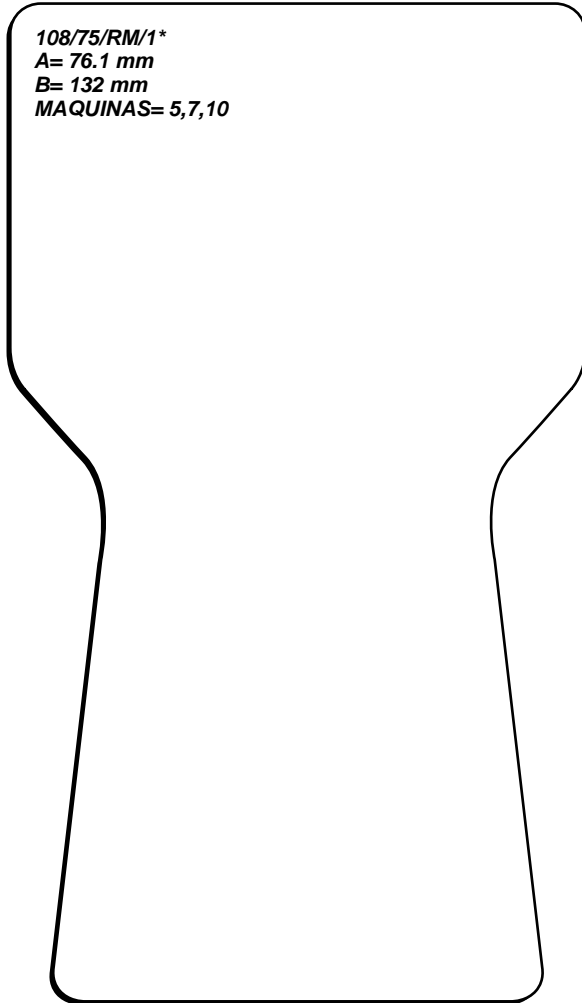



SUAJE DE 2 CAVIDADES
IMAGEN ESPEJO UNA DE LA OTRA
PARA FRENTE Y REVERSO

832/117/2*
A= 142.7 mm
B= 175 mm
MAQUINAS= 3,4

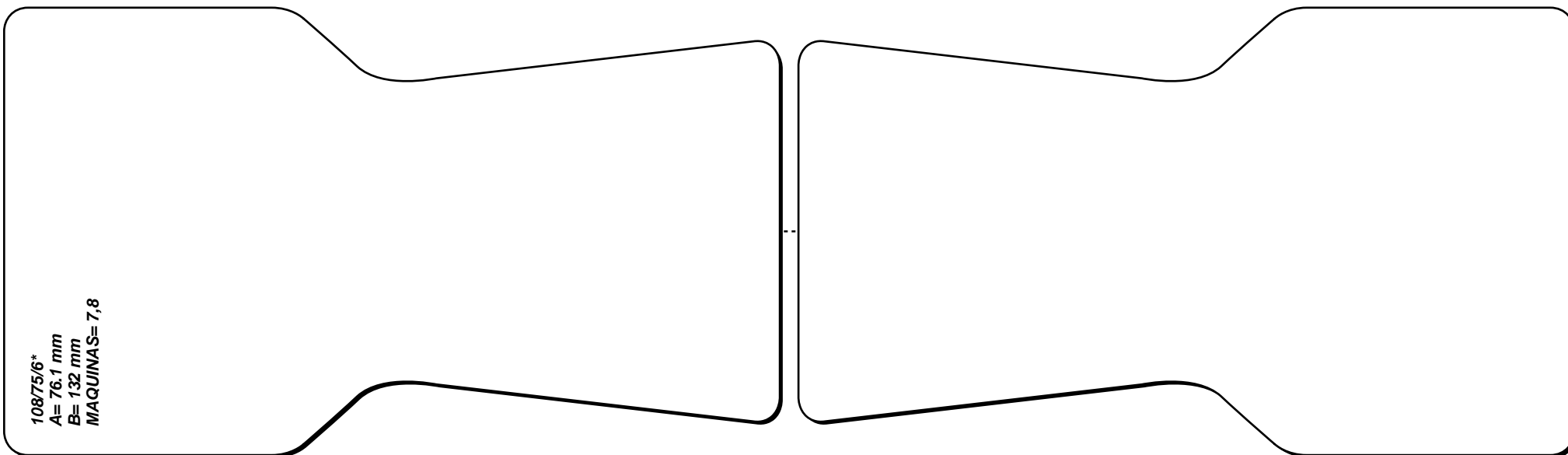
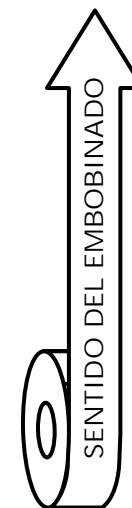
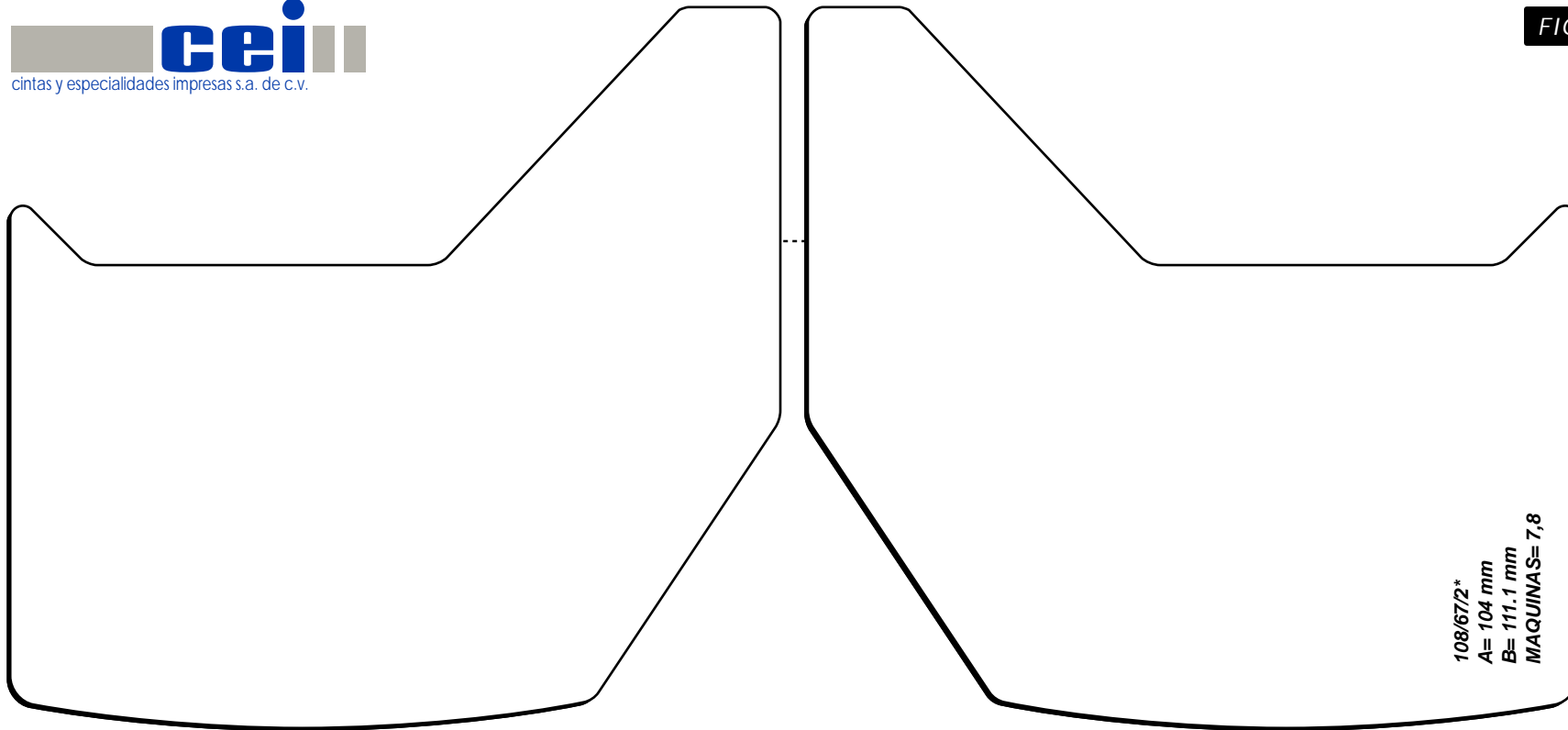

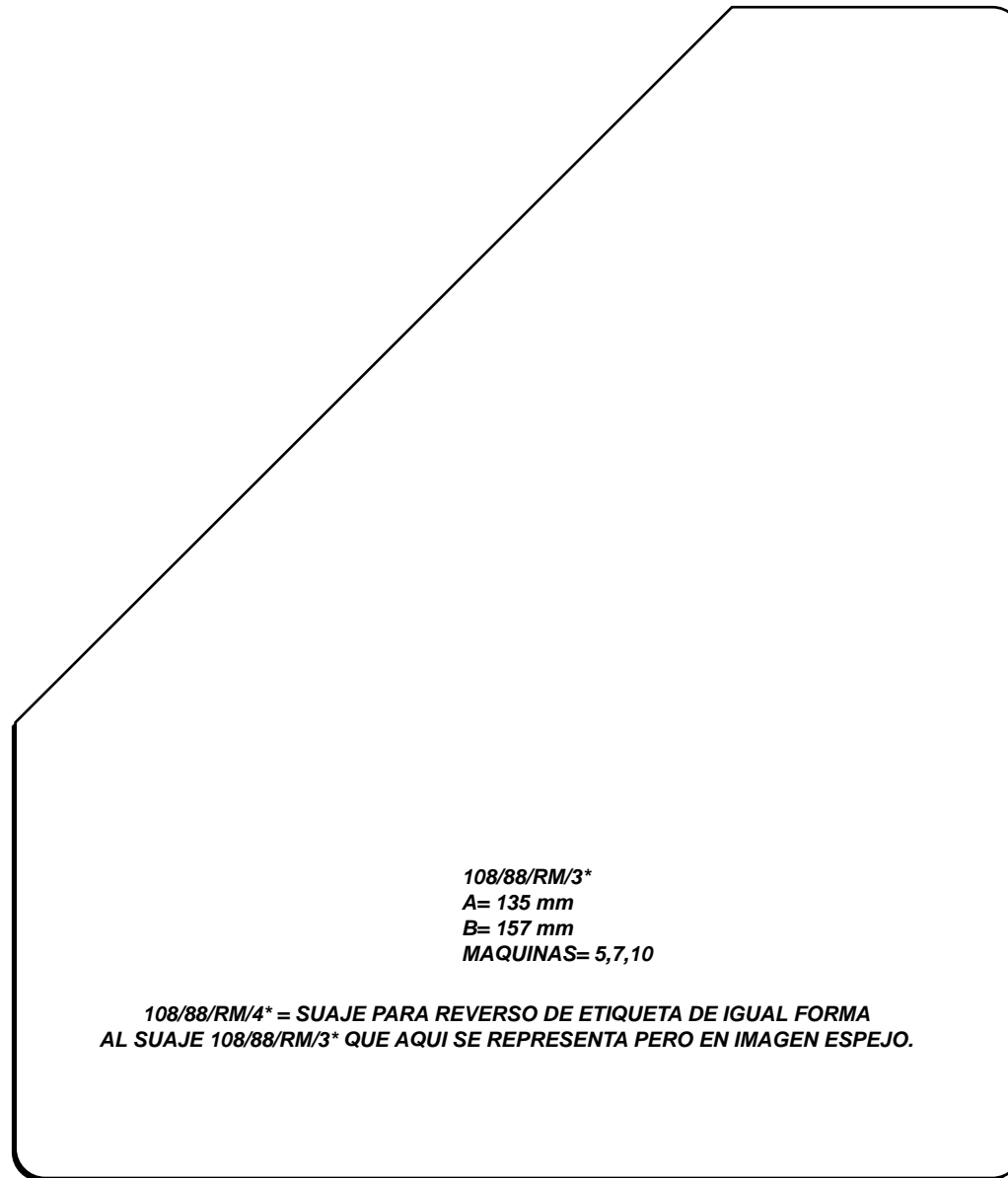

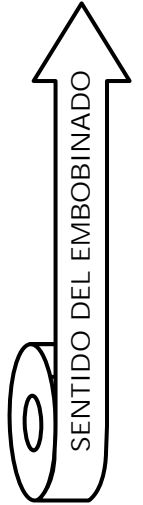
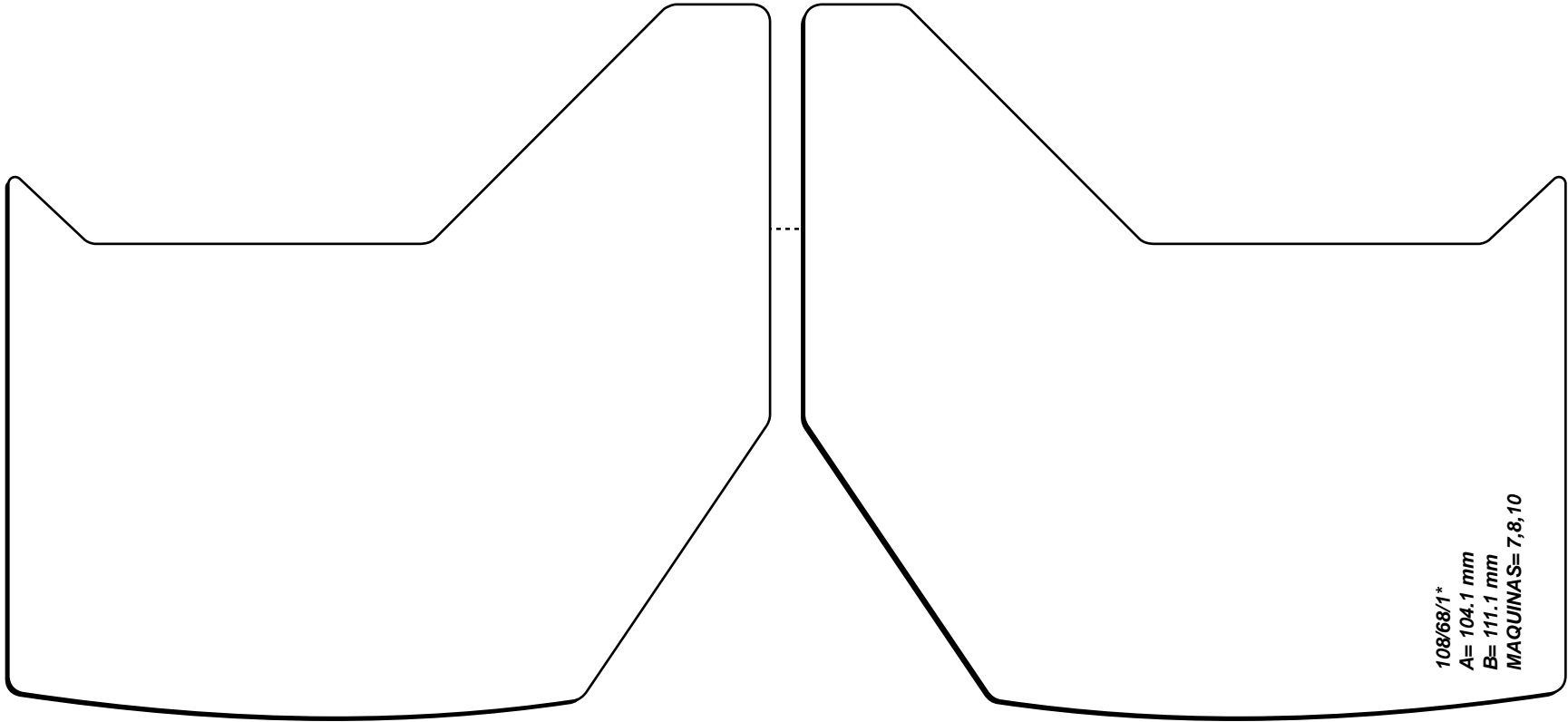
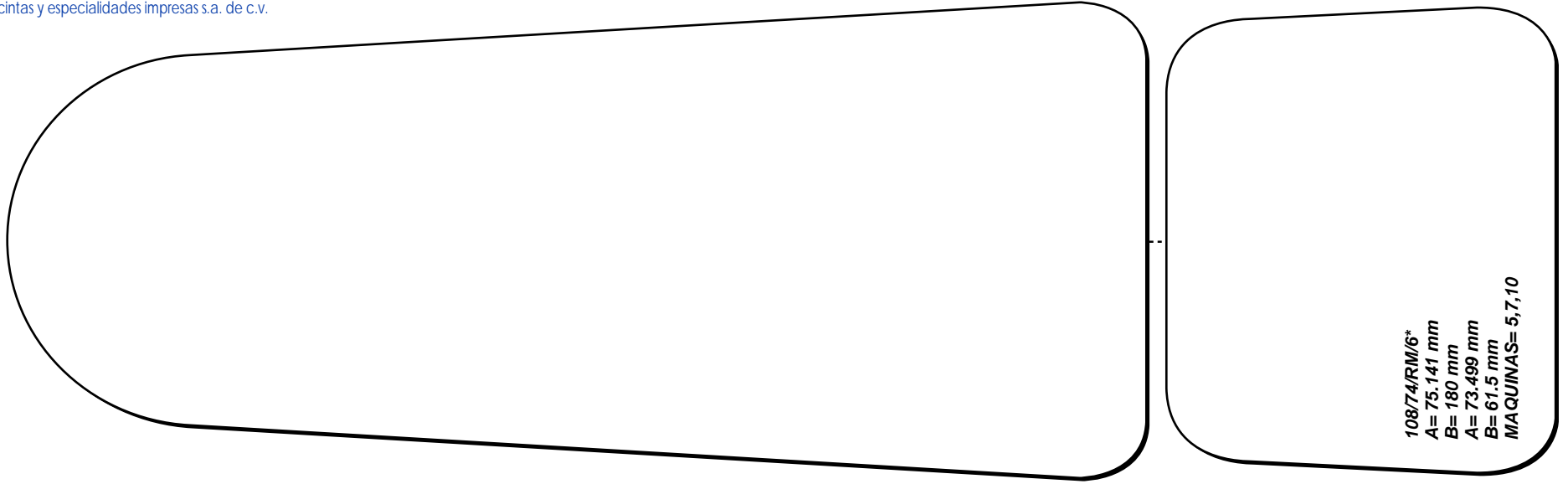



632/127/1*
A= 314.1 mm
B= 140 mm
MAQUINAS= 3,4

IMPRESO EN REDUCCION AL 75%

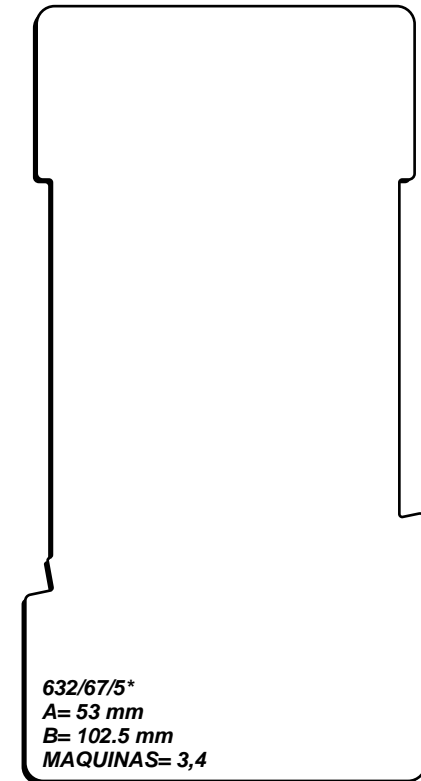
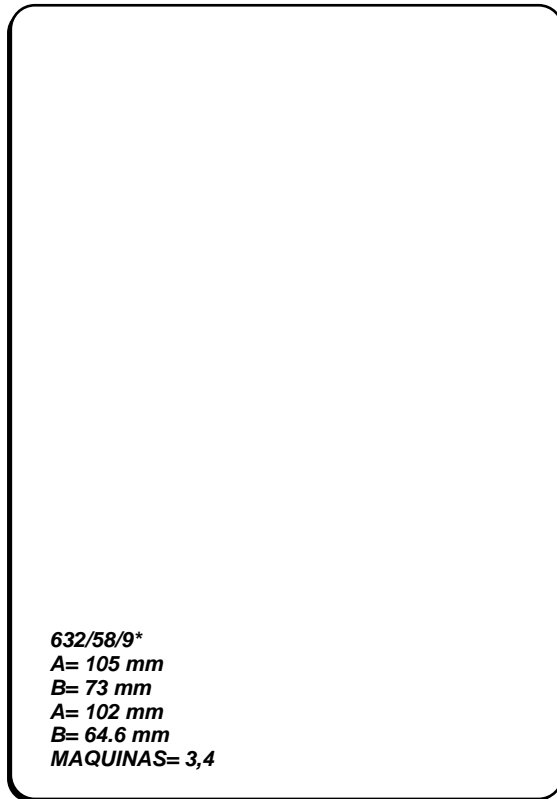



IMPRESO EN REDUCCION AL 90%

108/76/RM/2*
A= 235 mm
B= 190 mm
MAQUINAS= 5,10

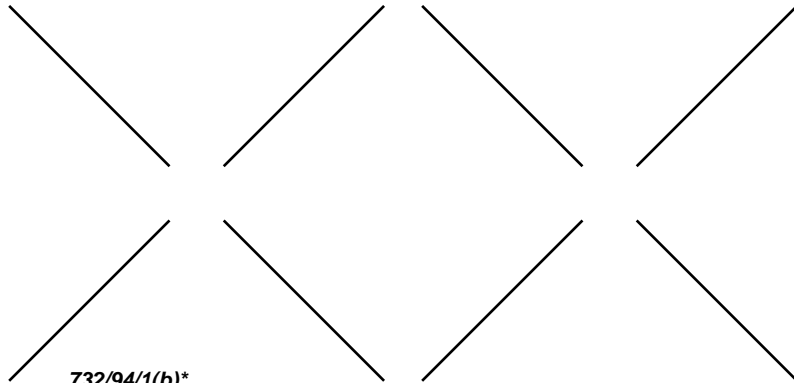

732/94/1(b)*
A= 104.23 mm
B= 49.60 mm
MAQUINAS= 3,4

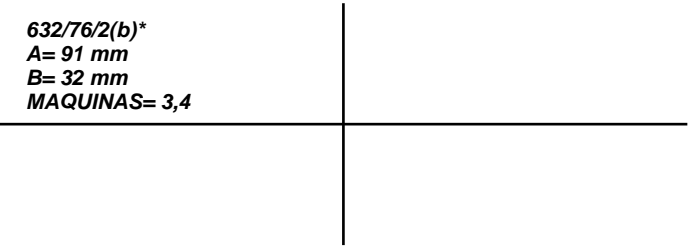

632/76/2(b)*
A= 91 mm
B= 32 mm
MAQUINAS= 3,4