



cintas y especialidades
impresas s.a. de c.v.

CATALOGO DE SUAJES

INDICE

GUIA PARA LA SELECCION DE SUAJES.....	Pag. 1
RECTANGULOS VERTICALES	Pag. 2 a la 5
CUADRADOS.....	Pag. 6
RECTANGULOS HORIZONTALES.....	Pag. 7 a la 22
CIRCULOS	Pag. 23
OVALOS	Pag. 24
FORMAS ESPECIALES.....	Pag. 25 a la 47
SUAJES DE CORTE COMPLETO Y CORTE ESPECIAL	Pag. 48 y 49

GUIA PARA LA SELECCION DE SUAJES

FORMA DEL SUAJE

MEDIDA: A= Medida en sentido longitudinal al rollo.

B= Medida en sentido transversal al rollo.

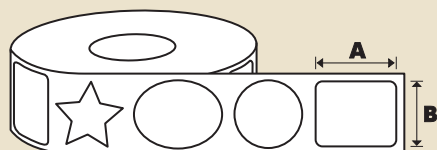

Fig. 1

108/54/2
A= 40 mm
B= 60 mm
MAQUINAS= 7,8

Fig. 2

MAQUINA: Indica la(s) máquina(s) en la(s) que se puede utilizar el suaje.
Revise la Fig. 3 para asegurarse que la combinación "SUAJE - MAQUINA" que selecciono se adecua a sus necesidades.

NUMERO DE SUAJE: Haga referencia a este número cuando seleccione el suaje.

CAPACIDAD DEL EQUIPO DE IMPRESION

MAQUINA	NUMERO DE TINTAS MAXIMO	ACABADOS DISPONIBLES	TIPO DE IMPRESION	TIRAJE
3	6 ó 5 + BARNIZ	LAMINACION BARNIZ U.V. BARNIZ STD.	TINTAS DIRECTAS Y SELECCION DE COLOR	BAJO ó MEDIO
4	6 ó 5 + BARNIZ	LAMINACION BARNIZ U.V. BARNIZ STD.	TINTAS DIRECTAS Y SELECCION DE COLOR	BAJO ó MEDIO
7	7 ó 6 + BARNIZ	LAMINACION BARNIZ U.V. BARNIZ STD.	TINTAS DIRECTAS Y SELECCION DE COLOR	MEDIO ó ALTO
8	6 ó 5 + BARNIZ	LAMINACION BARNIZ U.V. BARNIZ STD.	TINTAS DIRECTAS Y SELECCION DE COLOR	MEDIO ó ALTO

Fig. 3

PARA VER EL CATALOGO COMPLETO VEA LAS PAGINAS 2 A LA 45

NOTA: Los suajes marcados con "*" son de uso exclusivo y requieren autorización para su uso.



cintas y especialidades
impresas s.a. de c.v.



SUAJES RECTANGULOS VERTICALES

732/62/1
A= 74 mm
B= 150 mm
MAQUINAS= 3,4

732/79/2
A= 62.7 mm
B= 147 mm
MAQUINAS= 3,4

732/79/4
A= 62.7 mm
B= 135 mm
MAQUINAS= 3,4

108/64/2
A= 47.6 mm
B= 101.6 mm
MAQUINAS= 7,8

108/68/4
A= 40 mm
B= 127 mm
MAQUINAS= 7,8

632/79/8
A= 29.65 mm
B= 63 mm
MAQUINAS= 3,4

108/62/6
A= 25 mm
B= 51 mm
MAQUINAS= 7,8

632/68/6
A= 25.3 mm
B= 100 mm
MAQUINAS= 3,4

632/53/1
A= 19 mm
B= 73 mm
MAQUINA= 3,4

632/46/1
632/69/5-V
A= 16 mm
B= 54 mm
MAQUINA= 3,4



cintas y especialidades
impresas s.a. de c.v.



SUAJES RECTANGULOS VERTICALES

108/84/6
A= 85 mm
B= 153 mm
MAQUINAS= 7,8

632/114/1
A= 67.9 mm
B= 122 mm
MAQUINAS= 3,4

108/74/3
A= 55 mm
B= 85 mm
MAQUINAS= 7,8

632/57/3
A= 25.4 mm
B= 38.1 mm
MAQUINAS= 3,4

108/54/2
A=40 mm
B= 60 mm
MAQUINAS= 7,8



cintas y especialidades
impresas s.a. de c.v.



SUAJES RECTANGULOS VERTICALES

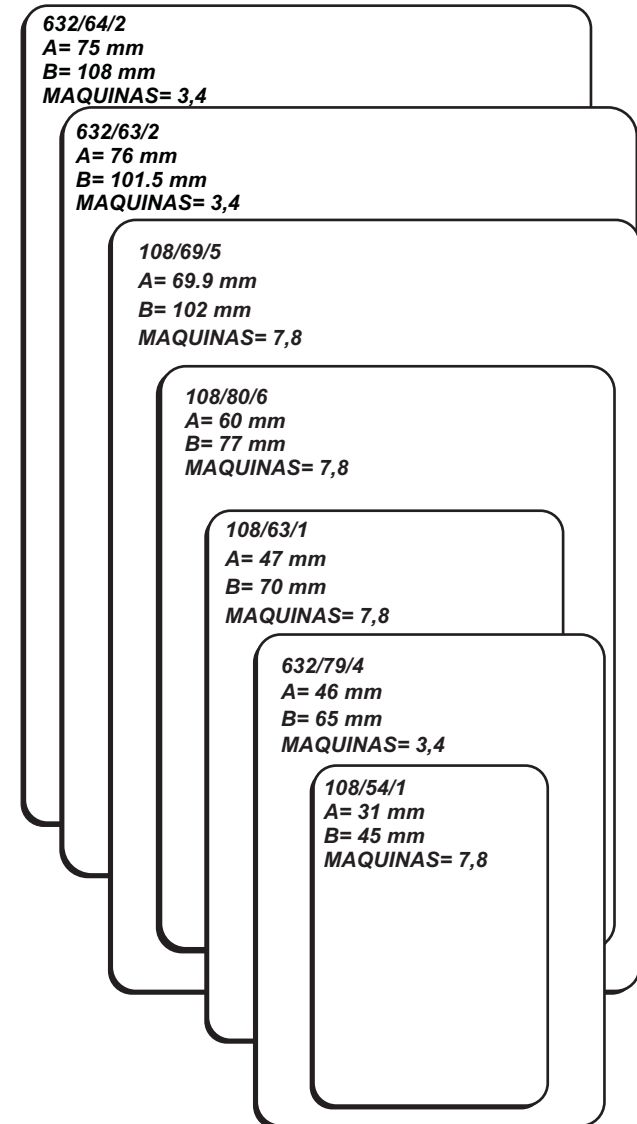
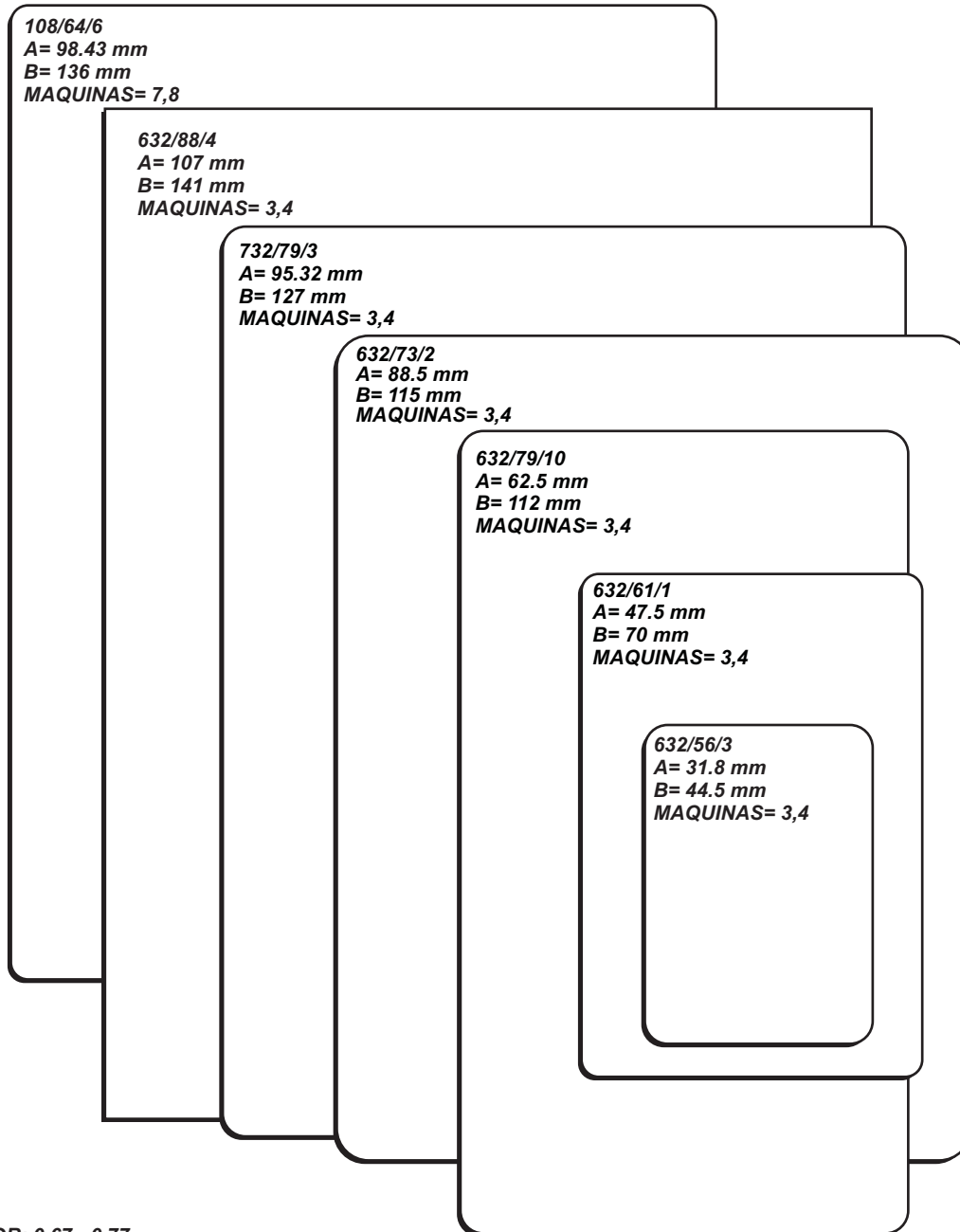



cintas y especialidades
impresas s.a. de c.v.

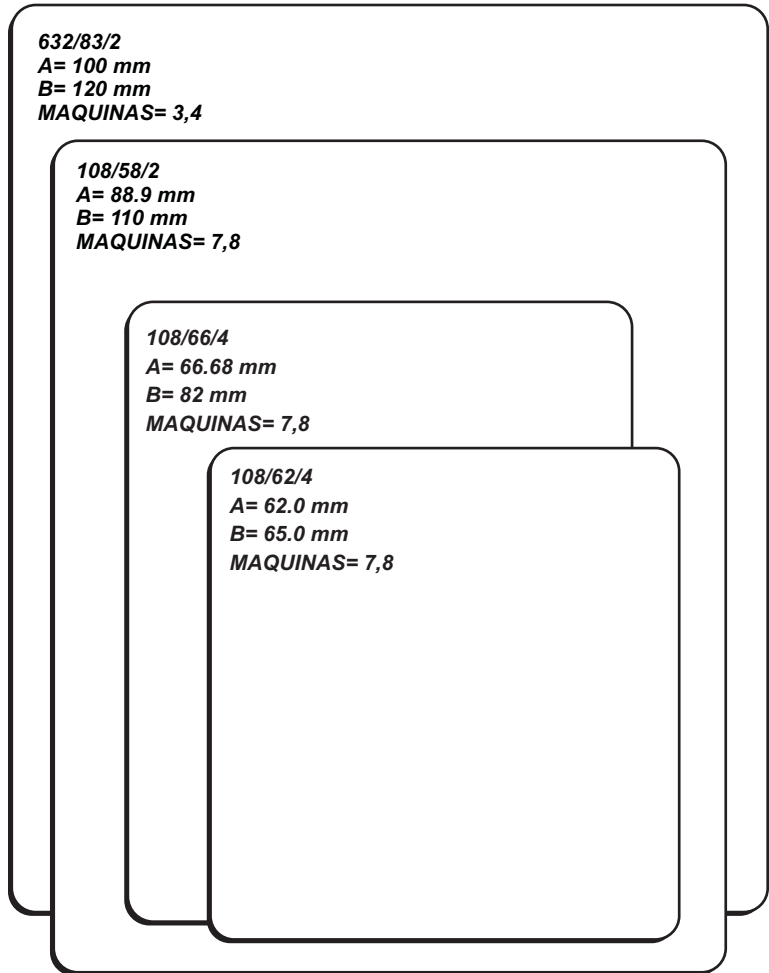
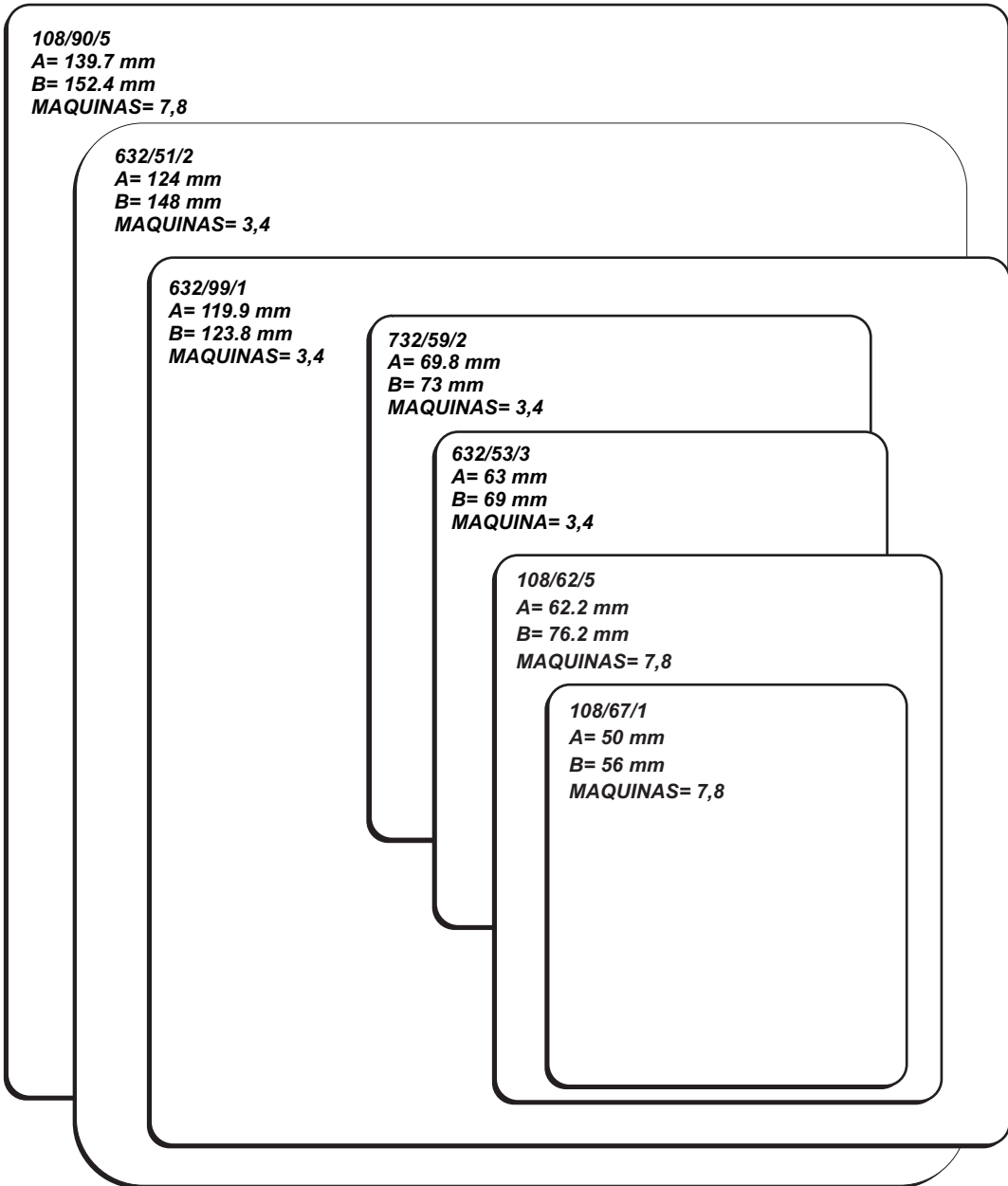



cintas y especialidades
impresas s.a. de c.v.



SUAJES CUADRADOS

108/78/7
A= 79.6 mm
B= 79.6 mm
MAQUINAS= 7,8

632/59/7
A= 70 mm
B= 70 mm
MAQUINAS= 3,4

108/69/1
A= 70 mm
B= 70 mm
MAQUINAS= 7,8

108/60/3
A= 60 mm
B= 60 mm
MAQUINAS= 7,8

632/69/3
A= 40 mm
B= 40 mm
MAQUINAS= 3,4

632/70/1
A= 31.7 mm
B= 31.7 mm
MAQUINAS= 3,4

632/60/2
A= 12 mm
B= 12 mm
MAQUINAS= 3,4



cintas y especialidades
impresas s.a. de c.v.



SUAJES RECTANGULOS HORIZONTALES

732/65/1
A= 159 mm
B= 154 mm
MAQUINAS= 3,4

632/57/4
A= 67.7 mm
B= 59.7 mm
MAQUINAS= 3,4

108/88/2
A= 90 mm
B= 80 mm
MAQUINAS= 7,8

108/65/1
A= 100 mm
B= 90 mm
MAQUINAS= 7,8

108/68/2
A= 50.8 mm
B= 44 mm
MAQUINAS= 7,8

632/71/2
A= 56 mm
B= 50 mm
MAQUINAS= 3,4

108/67/5
A= 67.63 mm
B= 60 mm
MAQUINAS= 7,8



cintas y especialidades
impresas s.a. de c.v.



SUAJES RECTANGULOS HORIZONTALES

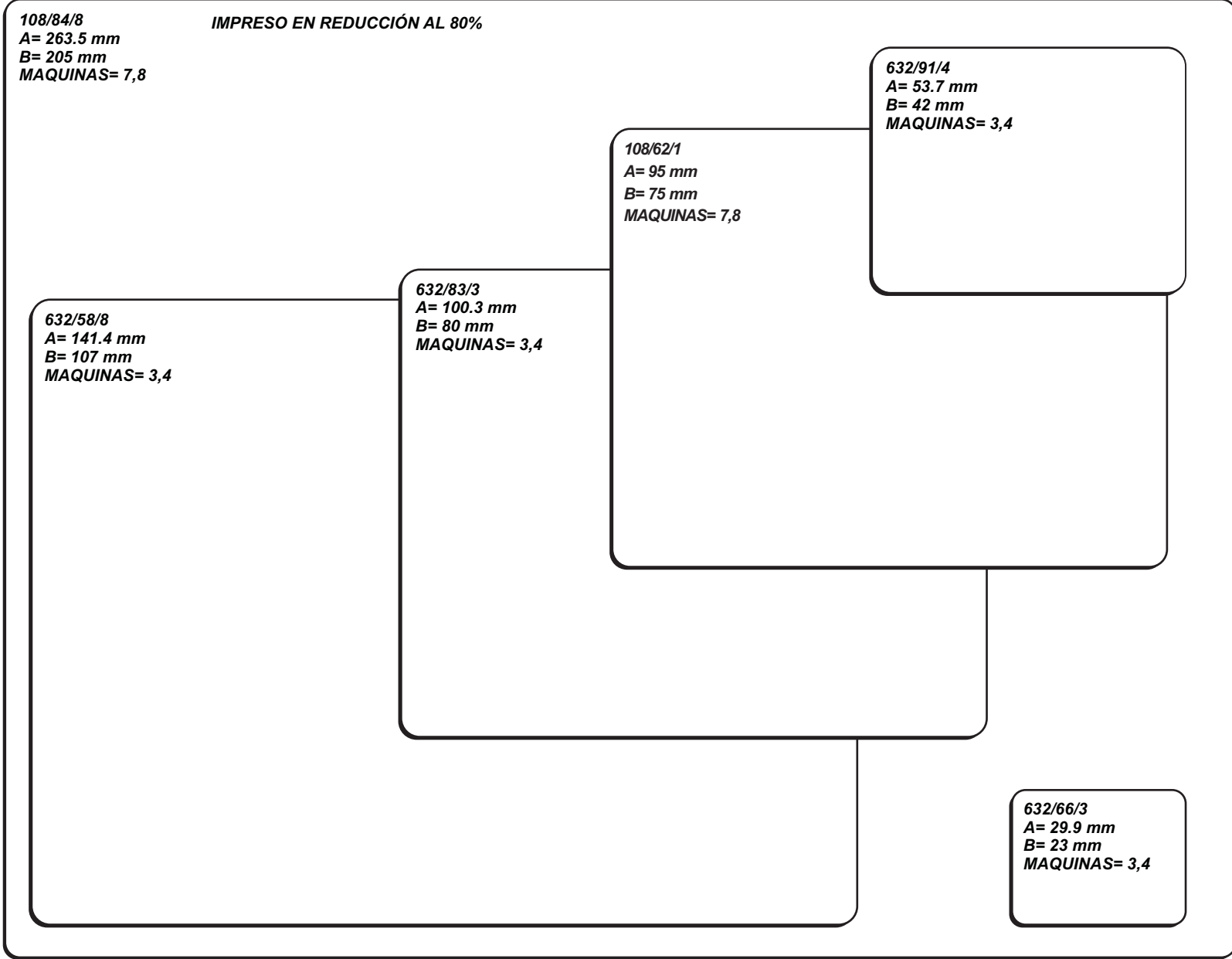

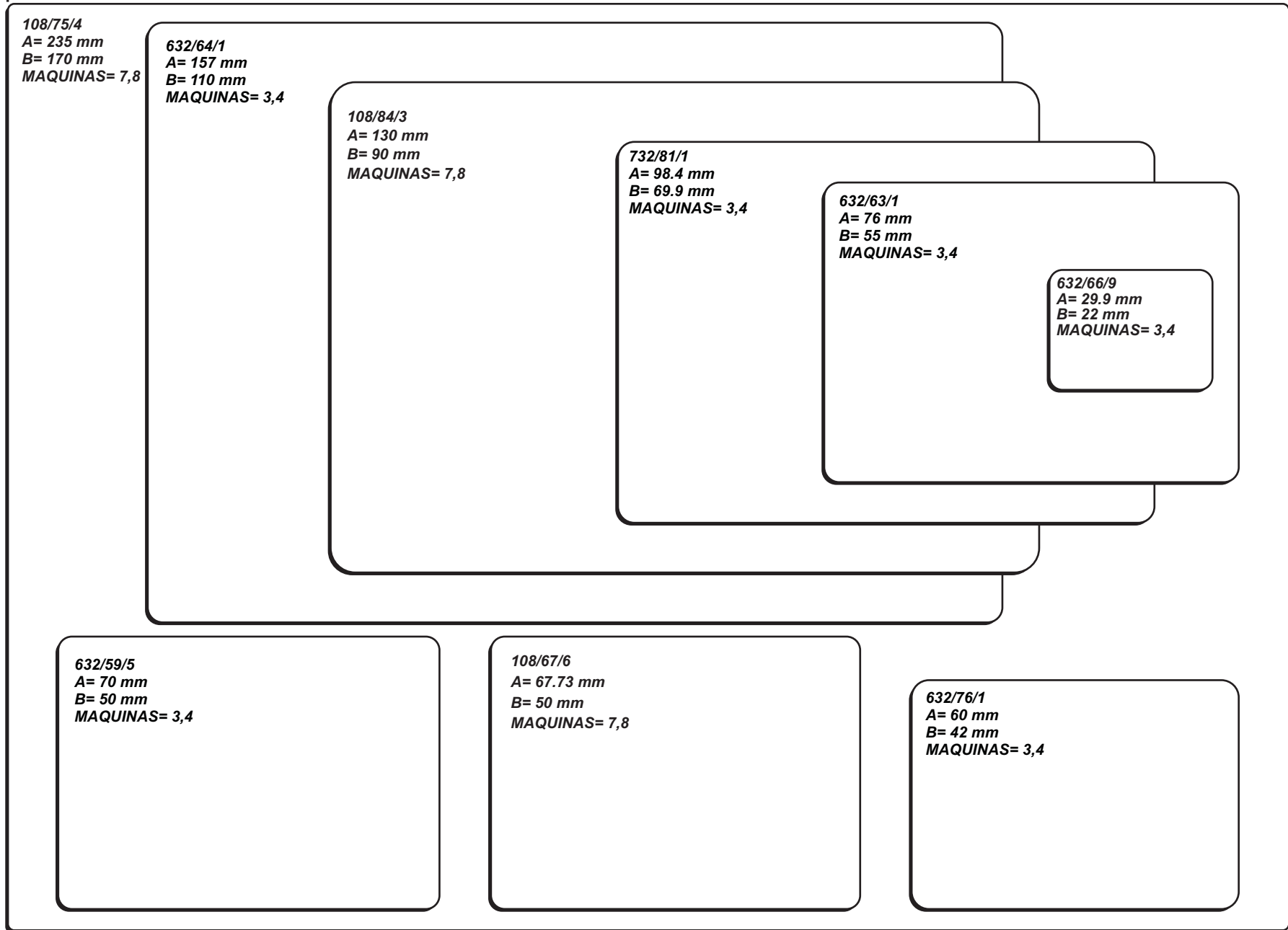



cintas y especialidades
impresas s.a. de c.v.



SUAJES RECTANGULOS HORIZONTALES

632/79/5
A= 193 mm
B= 130 mm
MAQUINAS= 3,4

732/62/2
A= 151.4 mm
B= 97 mm
MAQUINAS= 3,4

108/84/4
A= 130.2 mm
B= 86.3 mm
MAQUINAS= 7,8

732/94/1
A= 114.3 mm
B= 76.2 mm
MAQUINAS= 3,4

732/74/1
A= 88.9 mm
B= 60.3 mm
MAQUINAS= 3,4

732/59/1
A= 69.9 mm
B= 44.5 mm
MAQUINAS= 3,4

632/76/7
A= 60 mm
B= 45 mm
MAQUINAS= 3,4

632/61/5
A= 47 mm
B= 30 mm
MAQUINAS= 3,4

632/66/2
A= 38 mm
B= 25 mm
MAQUINAS= 3,4



cintas y especialidades
impresas s.a. de c.v.



SUAJES RECTANGULOS HORIZONTALES

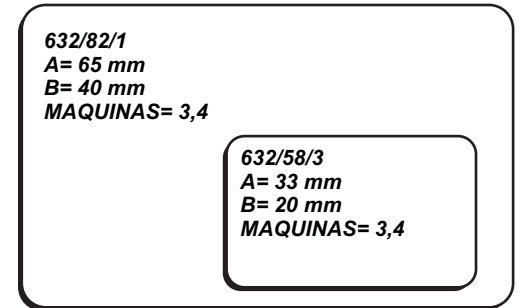
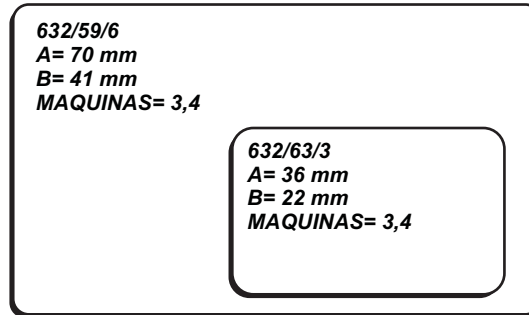
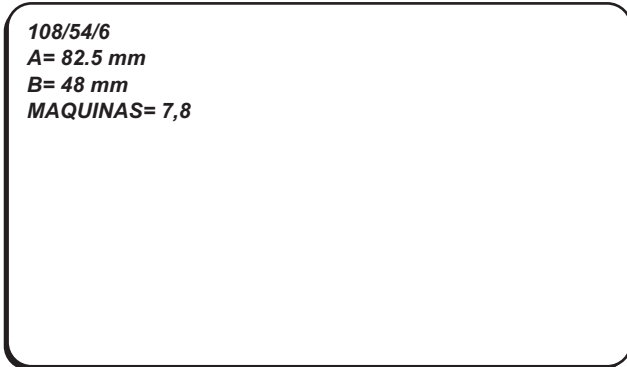
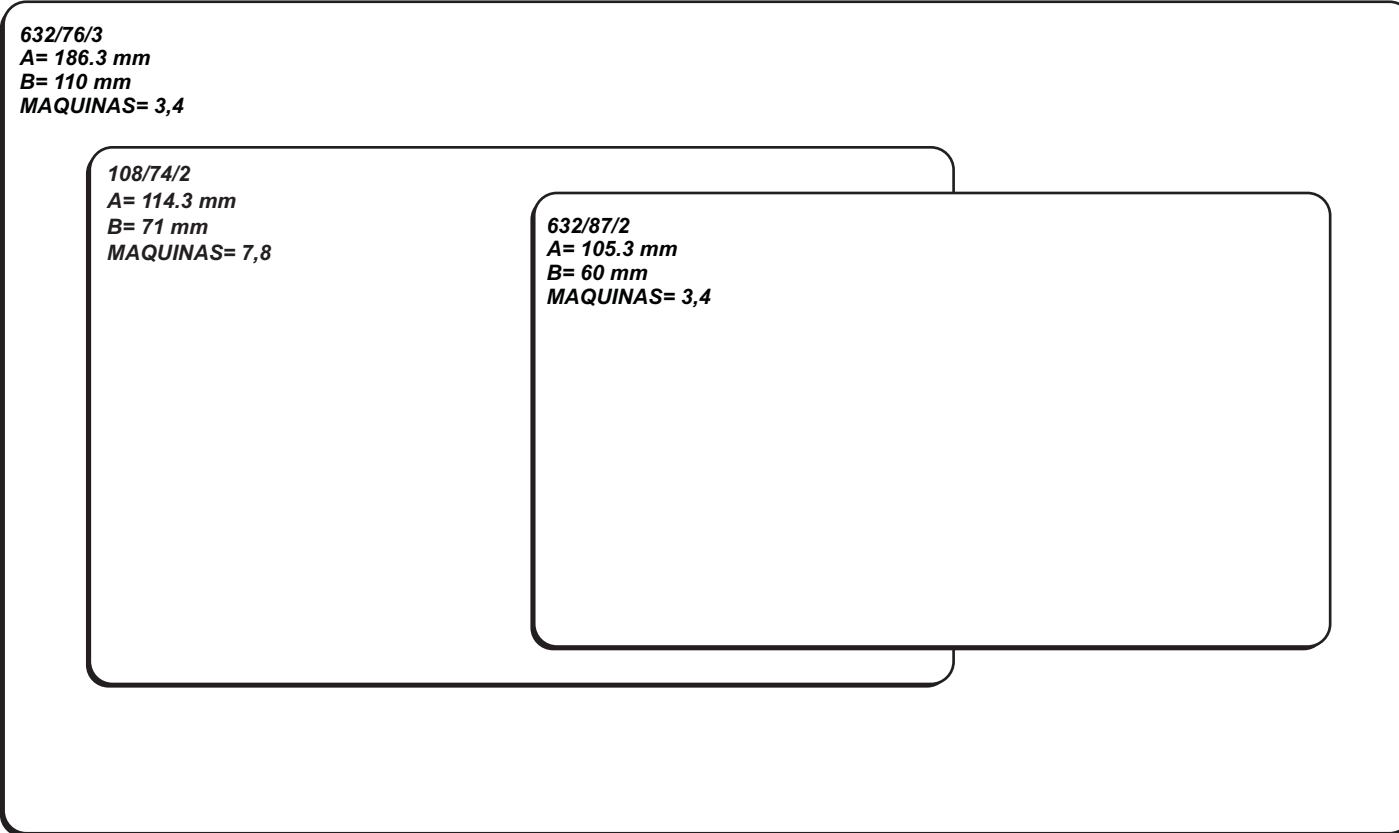



cintas y especialidades
impresas s.a. de c.v.

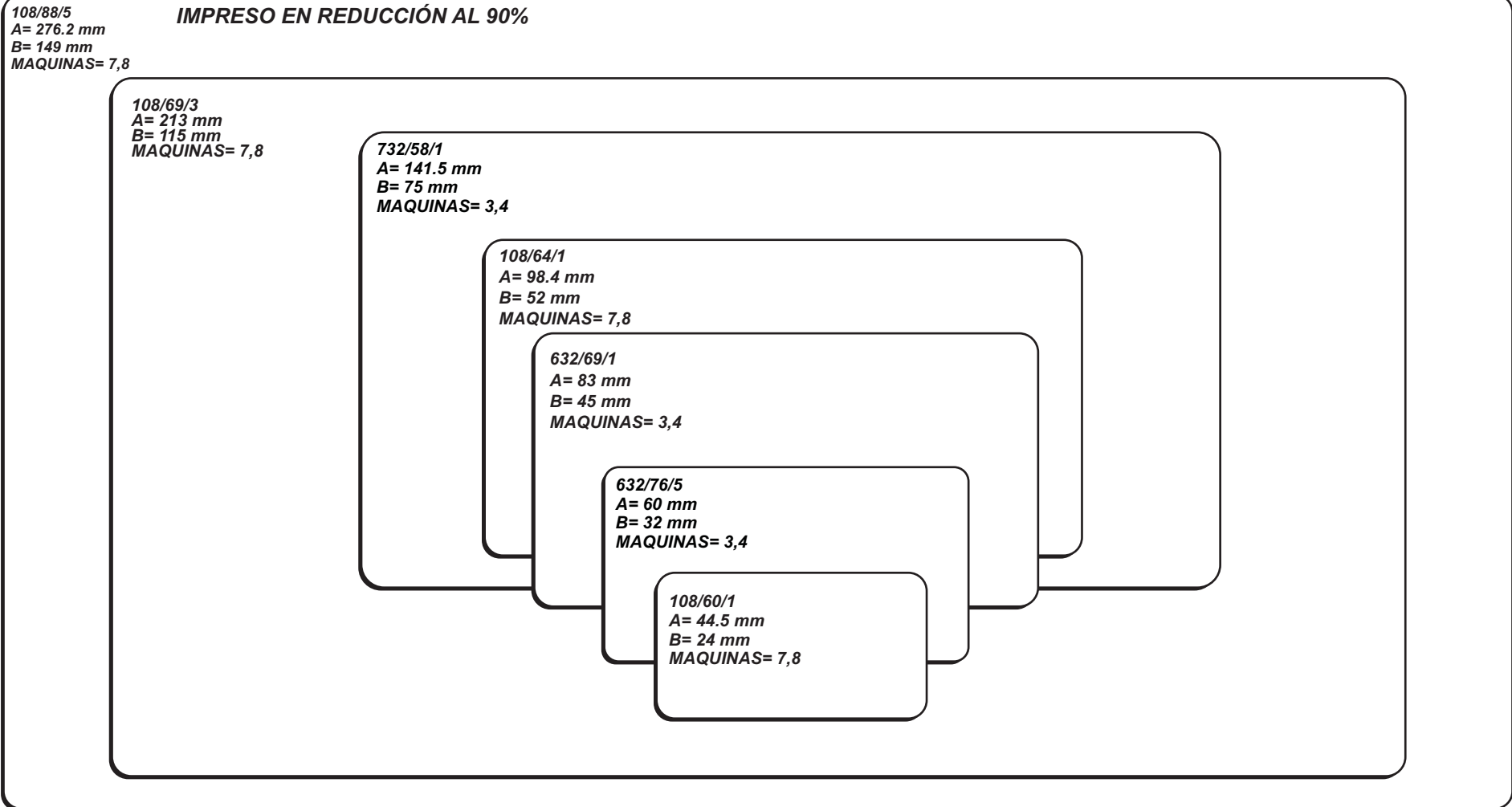



cintas y especialidades
impresas s.a. de c.v.



SUAJES RECTANGULOS HORIZONTALES

108/82/5
A= 257.35 mm
B= 135 mm
MAQUINAS= 7,8

108/102/1 **IMPRESO EN REDUCCION AL 75%**
A= 319.5 mm
B= 160.5 mm
MAQUINAS= 7,8

632/72/1
A= 176 mm
B= 90 mm
MAQUINAS= 3,4

108/90/2
A= 139.7 mm
B= 70 mm
MAQUINAS= 7,8

108/74/1
A= 114.4 mm
B= 57.15 mm
MAQUINAS= 7,8

632/73/1
A= 88 mm
B= 45 mm
MAQUINAS= 3,4

632/54/1
A= 64 mm
B= 32 mm
MAQUINAS= 3,4



cintas y especialidades
impresas s.a. de c.v.

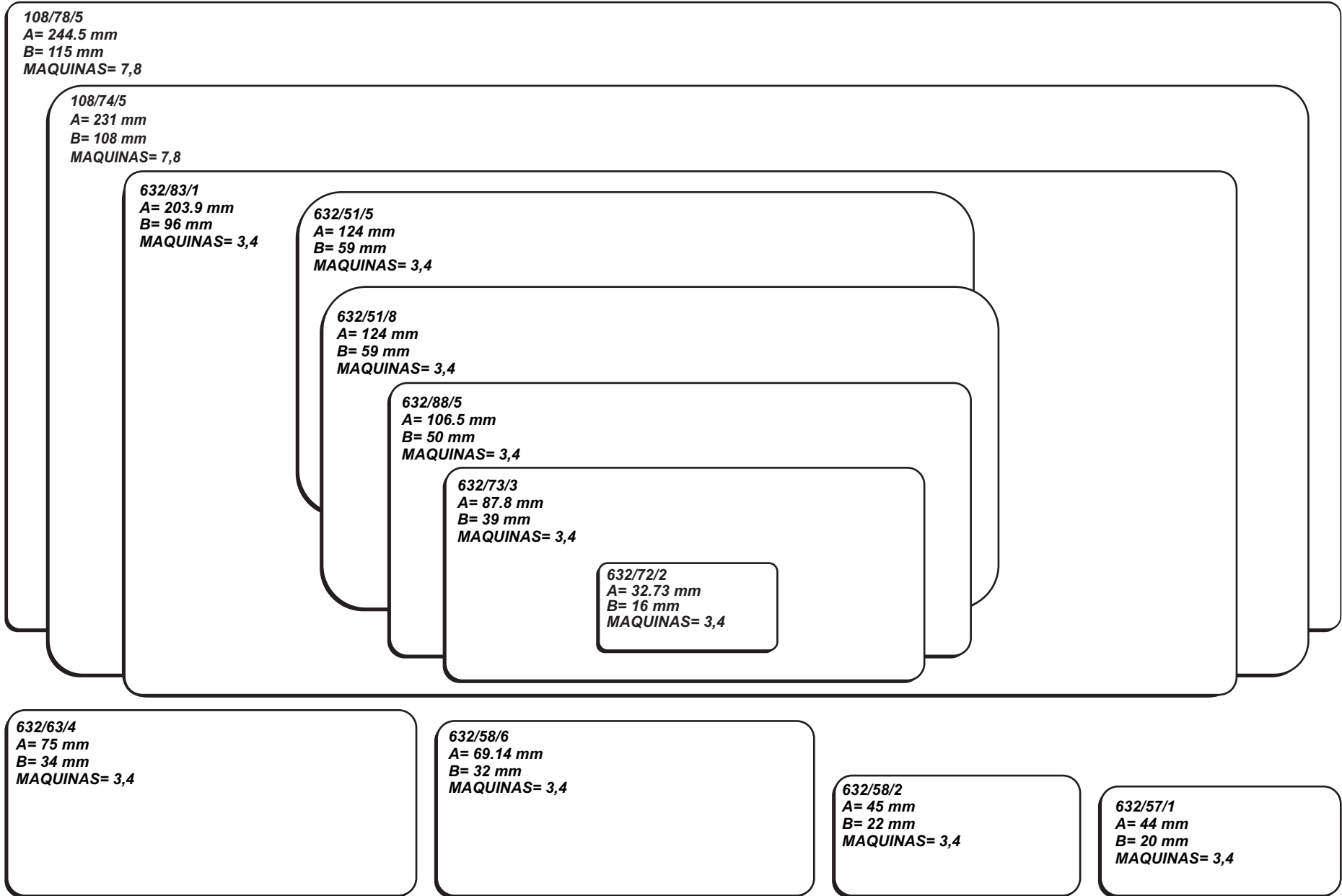



cintas y especialidades
impresas s.a. de c.v.

108/84/2 **IMPRESO EN REDUCCION AL 97%**
A= 264 mm
B= 110 mm
MAQUINAS= 7,8

108/84/1 **IMPRESO EN REDUCCION AL 97%**
A= 263 mm
B= 108 mm
MAQUINAS= 7,8

108/81/3
A= 252 mm
B= 103 mm
MAQUINAS= 7,8

632/87/3
A= 213.8 mm
B= 94 mm
MAQUINAS= 3,4

108/55/3
A= 171 mm
B= 75 mm
MAQUINAS= 7,8

108/66/1
A= 101.6 mm
B= 44.5 mm
MAQUINAS= 7,8

632/63/7
A= 36.1 mm
B= 16 mm
MAQUINAS= 3,4

632/76/6
A= 60 mm
B= 25 mm
MAQUINAS= 3,4

632/64/8
A= 76.2 mm
B= 32 mm
MAQUINAS= 3,4



cintas y especialidades
impresas s.a. de c.v.



SUAJES RECTANGULOS HORIZONTALES

108/78/1
A= 245 mm
B= 95 mm
MAQUINAS= 7,8

632/71/4
A= 173.5 mm
B= 70 mm
MAQUINAS= 3,4

632/58/5
A= 141 mm
B= 57 mm
MAQUINAS= 3,4

108/90/1
A= 139.7 mm
B= 57 mm
MAQUINAS= 7,8

108/80/4
A= 123.5 mm
B= 50 mm
MAQUINAS= 7,8

632/68/5
A= 81 mm
B= 32 mm
MAQUINAS= 3,4



cintas y especialidades
impresas s.a. de c.v.

108/102/2* IMPRESO EN REDUCCION AL 85%
A= 314 mm
B= 114 mm
MAQUINAS= 7,8

108/81/4
A= 254 mm
B= 96 mm
MAQUINAS= 7,8

108/77/1
A= 240.5 mm
B= 93 mm
MAQUINAS= 7,8

108/69/7
A= 215 mm
B= 80 mm
MAQUINAS= 7,8

108/64/8
A= 200 mm
B= 75 mm
MAQUINAS= 7,8

632/65/1
A= 159 mm
B= 58 mm
MAQUINAS= 3,4

632/65/5
A= 159 mm
B= 59 mm
MAQUINAS= 3,4

108/95/1
A= 147.63 mm
B= 55 mm
MAQUINAS= 7,8

632/70/2
A= 84 mm
B= 30 mm
MAQUINAS= 3,4



cintas y especialidades
impresas s.a. de c.v.



SUAJES RECTANGULOS HORIZONTALES

108/92/1 **IMPRESO EN REDUCCION AL 90%**
A= 289 mm
B= 95 mm
MAQUINAS= 7,8

108/78/6
A= 244.5 mm
B= 85 mm
MAQUINAS= 7,8

108/53/1
A= 165 mm
B= 57 mm
MAQUINAS= 7,8

632/66/6
A= 161.5 mm
B= 57 mm
MAQUINAS= 3,4

632/88/2
A= 106.5 mm
B= 36 mm
MAQUINAS= 3,4

632/53/5
A= 63 mm
B= 22 mm
MAQUINAS= 3,4

632/76/2
A= 91 mm
B= 32 mm
MAQUINAS= 3,4

632/64/7
A= 76.6 mm
B= 27 mm
MAQUINAS= 3,4

632/64/10
A= 76 mm
B= 25 mm
MAQUINAS= 3,4



cintas y especialidades
impresas s.a. de c.v.



SUAJES RECTANGULOS HORIZONTALES

108/147/1 **IMPRESO EN REDUCCION AL 55%**

A= 464 mm

B= 142 mm

MAQUINAS= 7,8

632/82/4

A= 201.3 mm

B= 62 mm

MAQUINAS= 3,4

632/99/2

A= 120.2 mm

B= 39 mm

MAQUINAS= 3,4

108/64/7

A= 200 mm

B= 62 mm

MAQUINAS= 7,8

632/65/4

A= 158.9 mm

B= 50 mm

MAQUINAS= 3,4

108/90/4

A= 139 mm

B= 42 mm

MAQUINAS= 7,8



cintas y especialidades
impresas s.a. de c.v.

108/147/2 IMPRESO EN REDUCCIÓN AL 55%
A= 463 mm
B= 134 mm
MAQUINAS= 7,8

108/80/5
A= 250.5 mm
B= 71 mm
MAQUINAS= 7,8

108/64/3
A= 200 mm
B= 58 mm
MAQUINAS= 7,8

632/79/9
A= 95.3 mm
B= 28 mm
MAQUINAS= 3,4

108/50/1
A= 76 mm
B= 22 mm
MAQUINAS= 7,8

108/81/5
A= 252 mm
B= 73 mm
MAQUINAS= 7,8

108/59/1
A= 184.15 mm
B= 53.5 mm
MAQUINAS= 7,8

108/55/2
A= 83.8 mm
B= 24 mm
MAQUINAS= 7,8

632/70/3
A= 83.8 mm
B= 24 mm
MAQUINAS= 3,4

632/68/7
A= 53 mm
B= 15 mm
MAQUINAS= 3,4

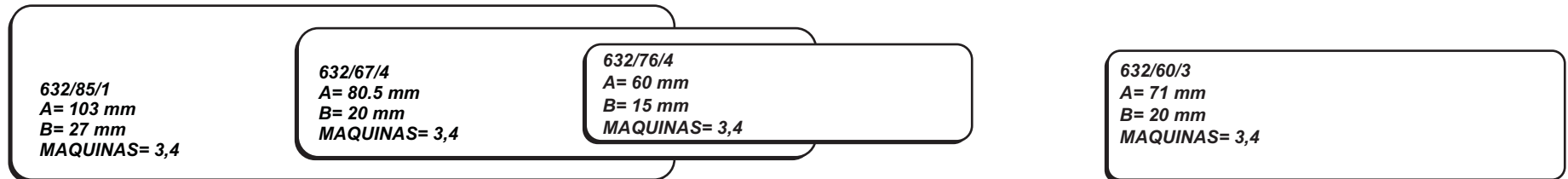
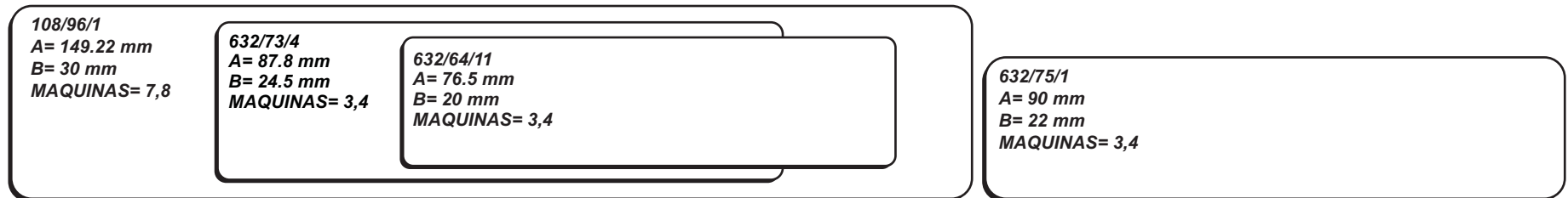
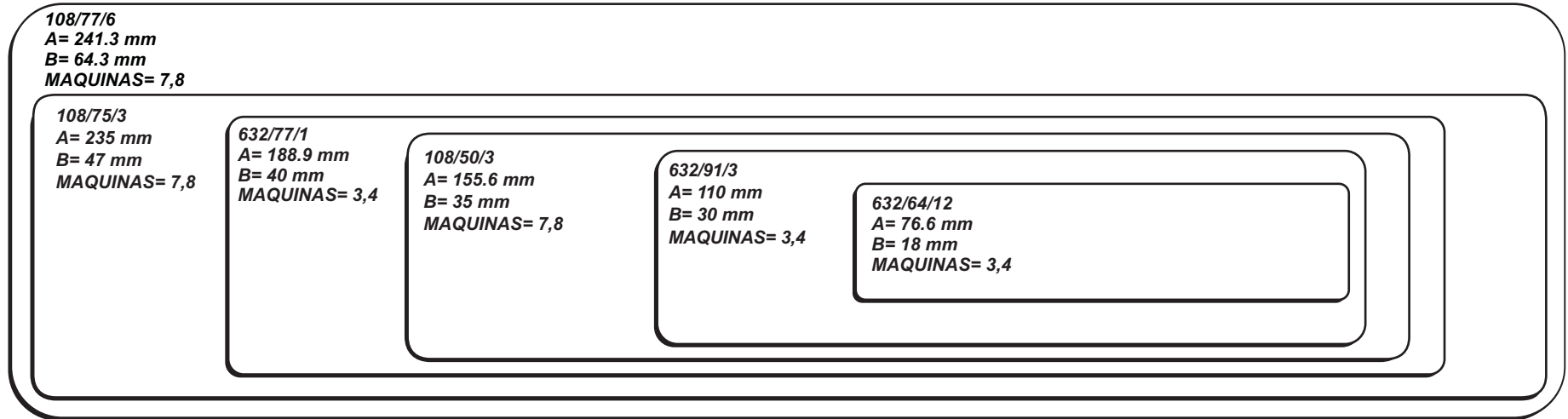



cintas y especialidades
impresas s.a. de c.v.

IMPRESO EN REDUCCION AL 90%

108/90/6
A= 282.57 mm
B= 50 mm
MAQUINAS= 7,8

108/80/3
A= 251.3 mm
B= 64 mm
MAQUINAS= 7,8

632/99/3
A= 243.7 mm
B= 42 mm
MAQUINAS= 3,4

108/60/10
A= 187.3 mm
B= 31 mm
MAQUINAS= 7,8

632/66/8
A= 161 mm
B= 31 mm
MAQUINAS= 3,4

632/51/6
A= 126.5 mm
B= 15 mm
MAQUINAS= 3,4

108/82/3 - 108/82/4
A= 257.1 mm
B= 40 mm
MAQUINAS= 7,8

108/74/7
A= 231.7 mm
B= 30 mm
MAQUINAS= 7,8

108/55/4
A= 171.5 mm
B= 30 mm
MAQUINAS= 7,8

108/54/3
A= 168.3 mm
B= 24 mm
MAQUINAS= 7,8

632/86/1
A= 104 mm
B= 18 mm
MAQUINAS= 3,4

632/88/1
A= 106.5 mm
B= 10 mm
MAQUINAS= 3,4

632/56/2
A= 31.7 mm
B= 6 mm
MAQUINAS= 3,4



cintas y especialidades
impresas s.a. de c.v.



SUAJES CIRCULOS

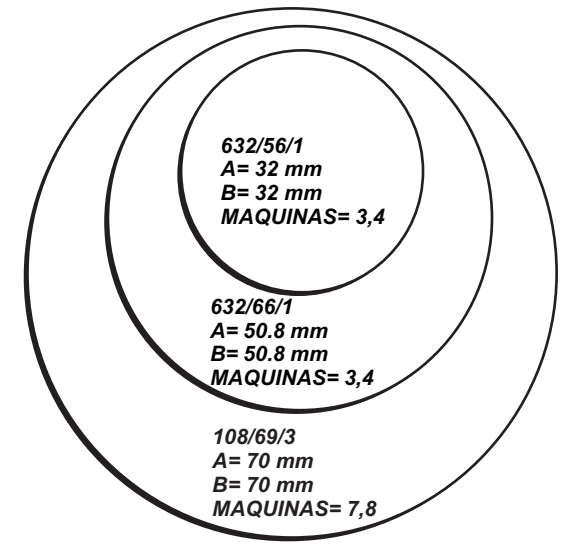
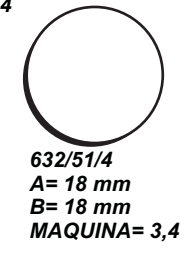
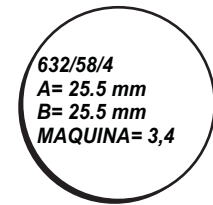
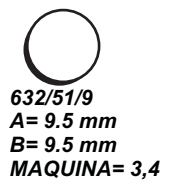
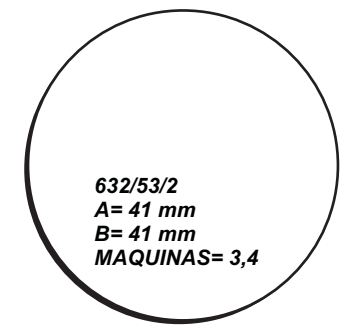
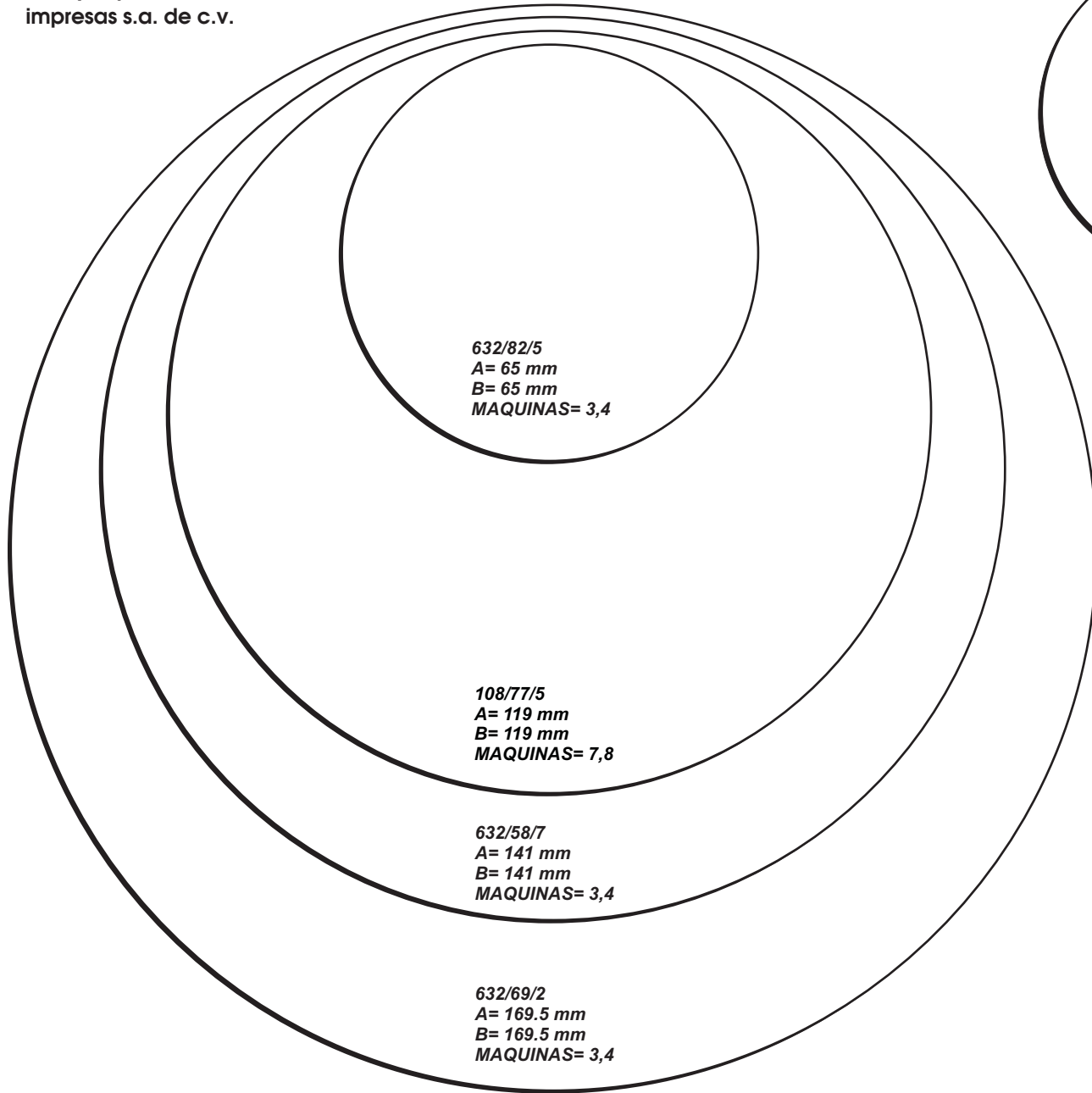



cintas y especialidades
impresas s.a. de c.v.

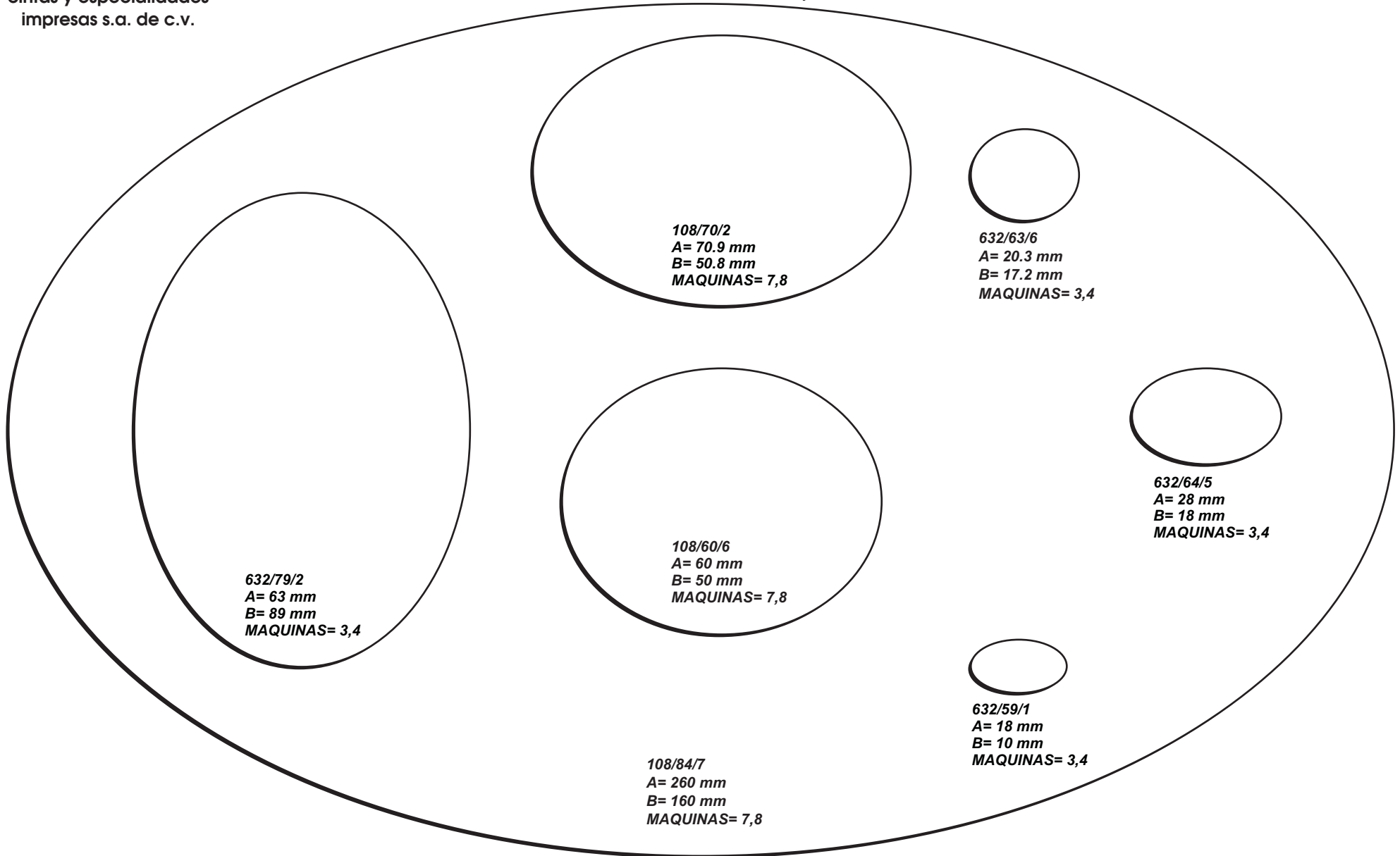



cintas y especialidades
impresas s.a. de c.v.

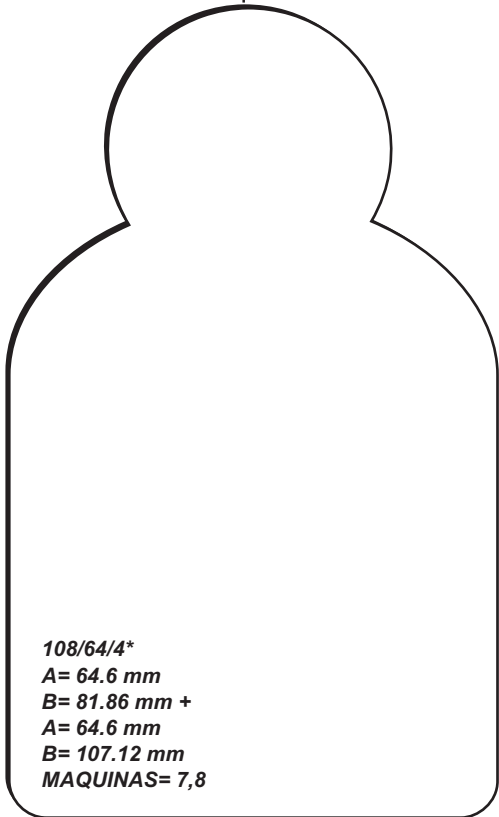
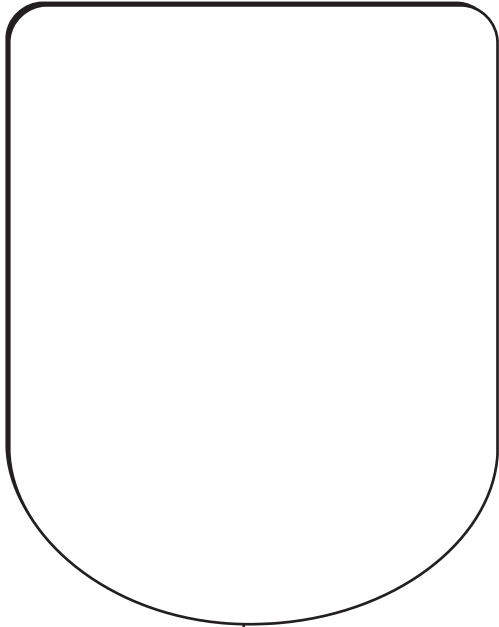

108/64/4*
A= 64.6 mm
B= 81.86 mm +
A= 64.6 mm
B= 107.12 mm
MAQUINAS= 7,8

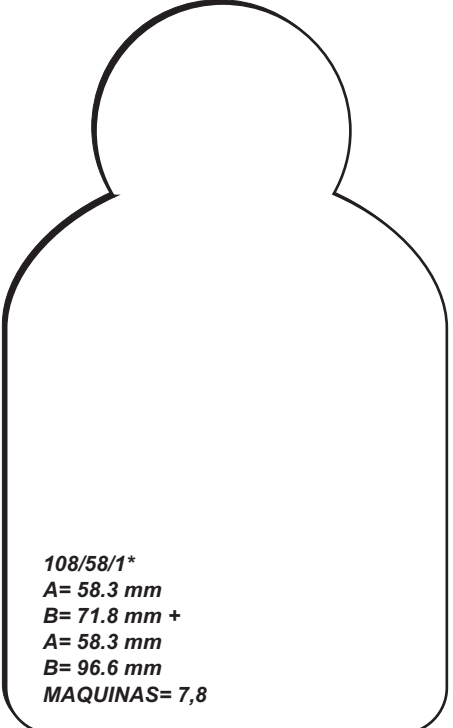
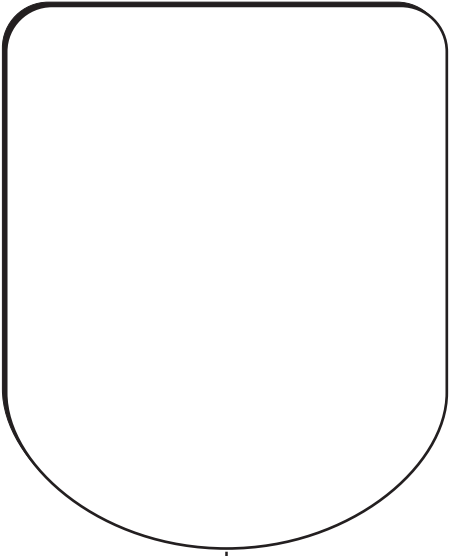

108/58/1*
A= 58.3 mm
B= 71.8 mm +
A= 58.3 mm
B= 96.6 mm
MAQUINAS= 7,8



cintas y especialidades
impresas s.a. de c.v.

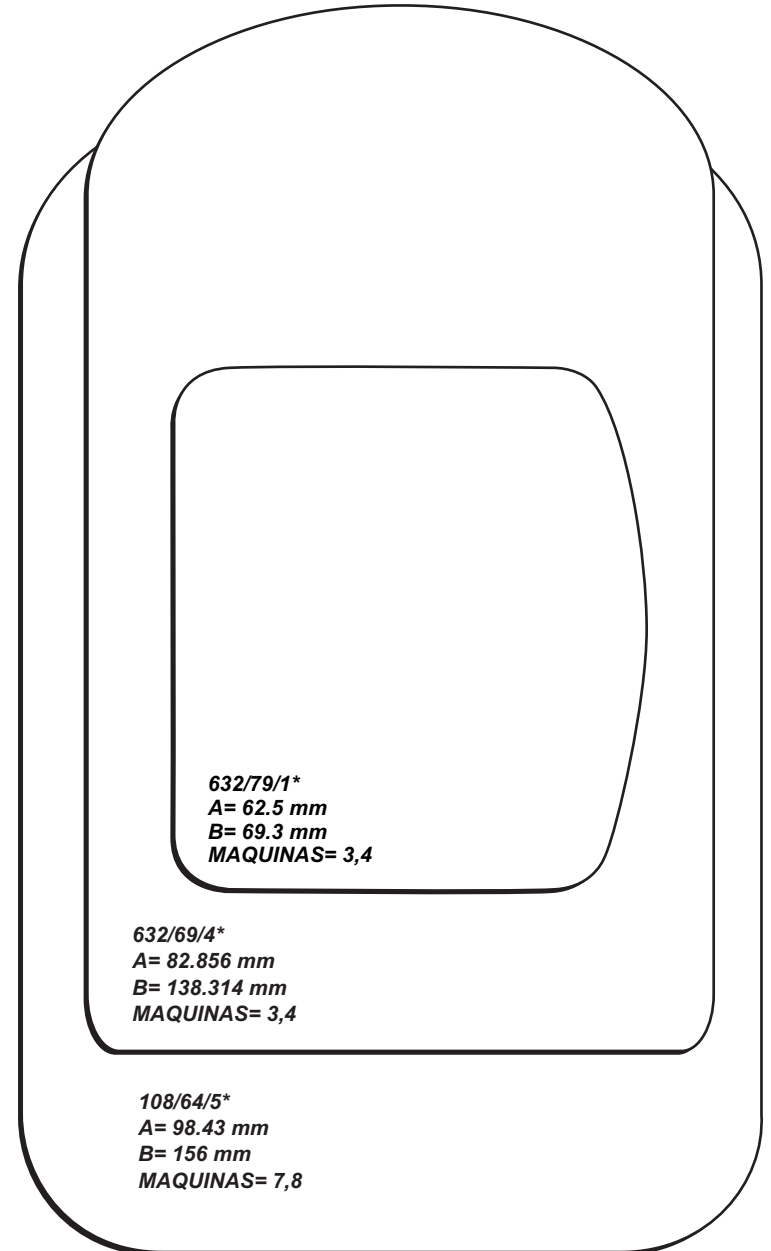
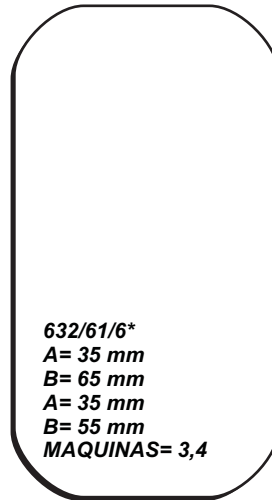
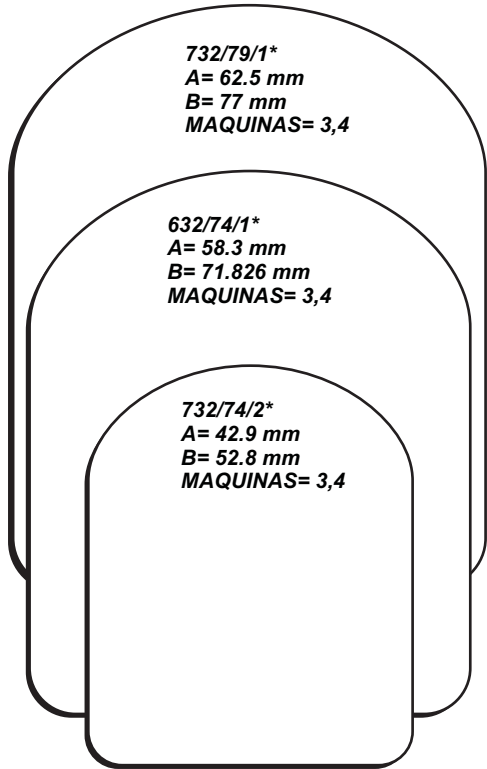



108/69/2*
A= 69.85 mm
B= 110.88 mm
MAQUINAS= 7,8

108/67/3*
A= 50.01 mm
B= 99.36 mm
MAQUINAS= 7,8

632/71/4*
A= 173.87 mm
B= 95 mm
MAQUINAS= 3,4

SUAJE DE 2 CAVIDADES
IMAGEN ESPEJO UNA DE LA OTRA
PARA FRENTE Y REVERSO

632/117/1*
A= 142.2 mm
B= 63.5 mm
MAQUINAS= 3,4

632/64/9 *
A= 76 mm
B= 52 mm
MAQUINAS= 3,4

SUAJE DE 2 CAVIDADES
IMAGEN ESPEJO UNA DE LA OTRA
PARA FRENTE Y REVERSO

632/67/2*
A= 163.5 mm
B= 77 mm
MAQUINAS= 3,4

732/71/1*
A= 84.93 mm
B= 63.5 mm
MAQUINAS= 3,4



632/73/5*
A= 178.8 mm
B= 60 mm
MAQUINAS= 3,4

632/59/9*
A= 70 mm
B= 130 mm
MAQUINAS= 3,4

108/66/2*
A= 66.6 mm
B= 103.5 mm
MAQUINAS= 7,8

108/66/3*
A= 38.7 mm
B= 61 mm
MAQUINAS= 7,8



cintas y especialidades
impresas s.a. de c.v.

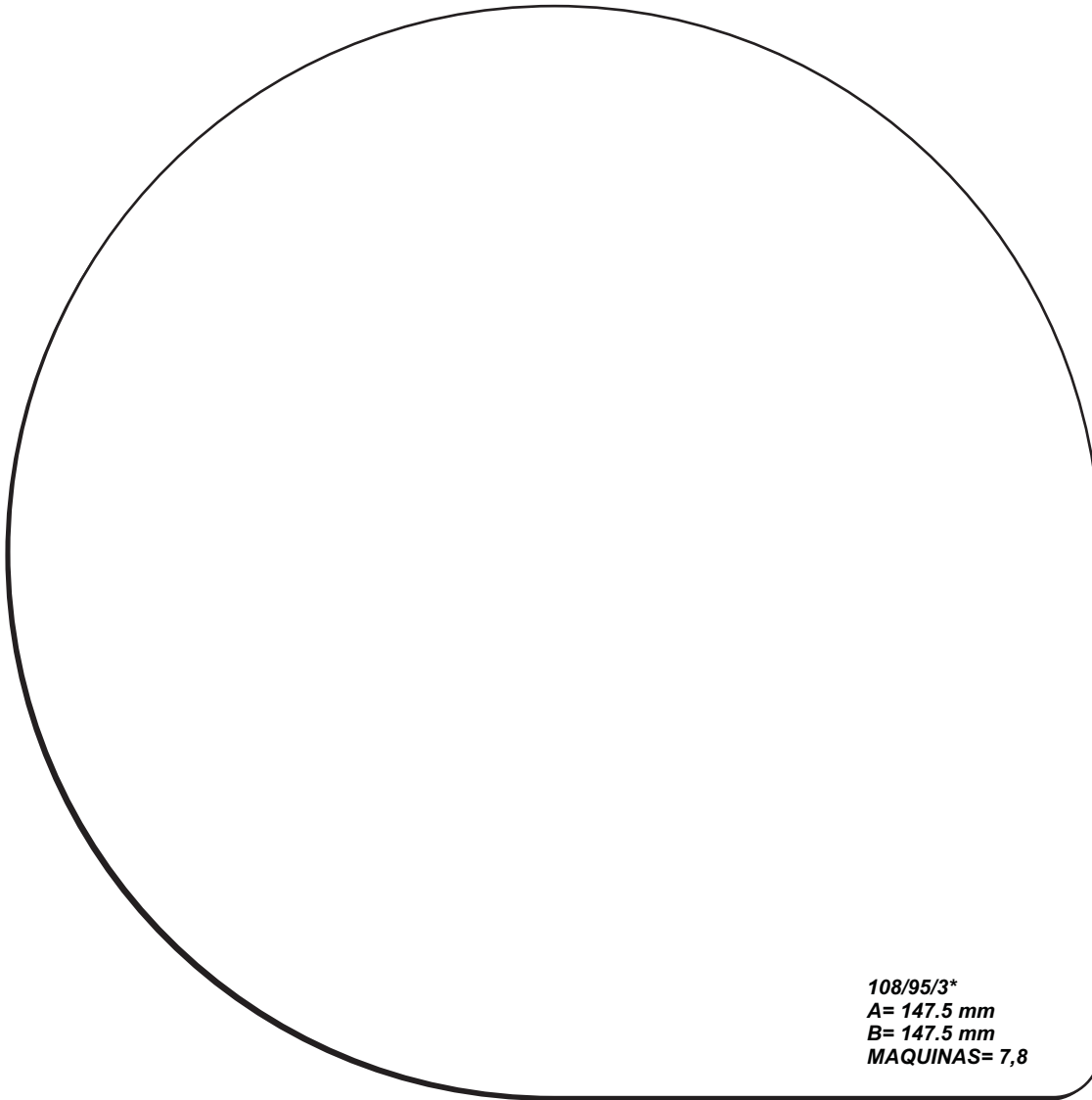

*108/95/3**
A= 147.5 mm
B= 147.5 mm
MAQUINAS= 7,8

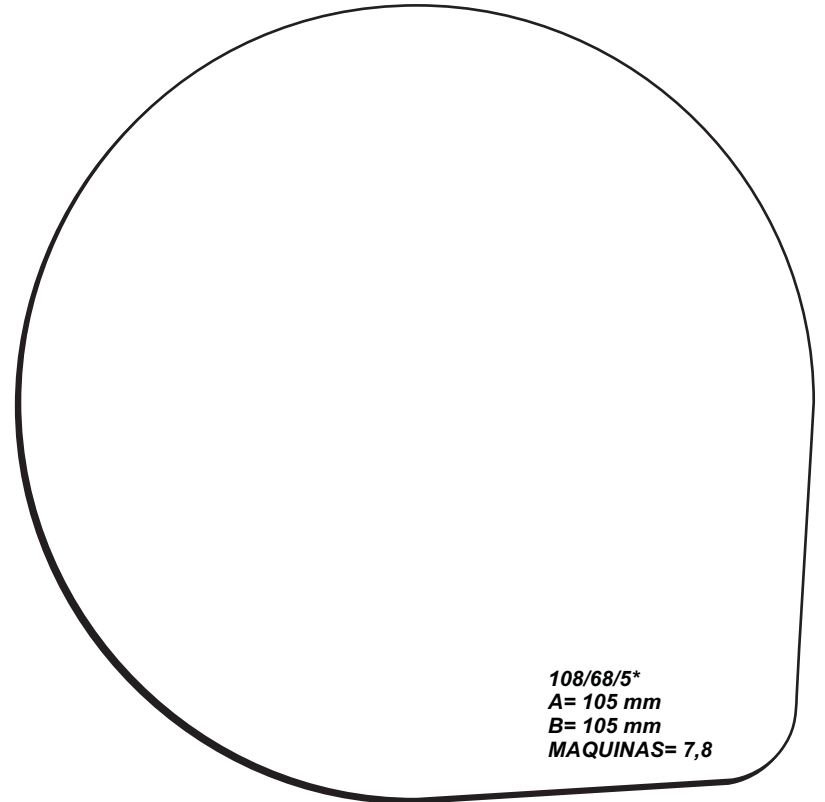

*108/68/5**
A= 105 mm
B= 105 mm
MAQUINAS= 7,8



cintas y especialidades
impresas s.a. de c.v.

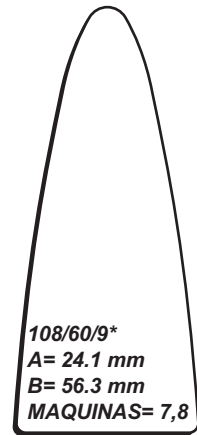
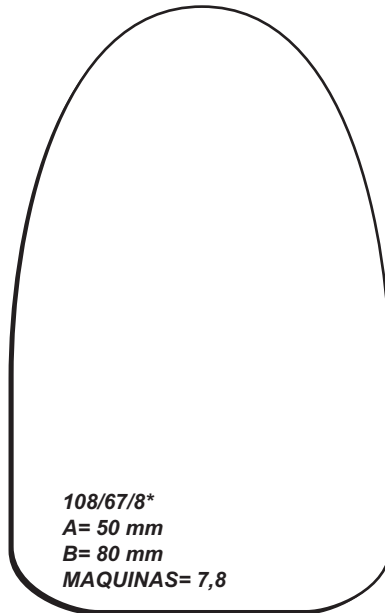
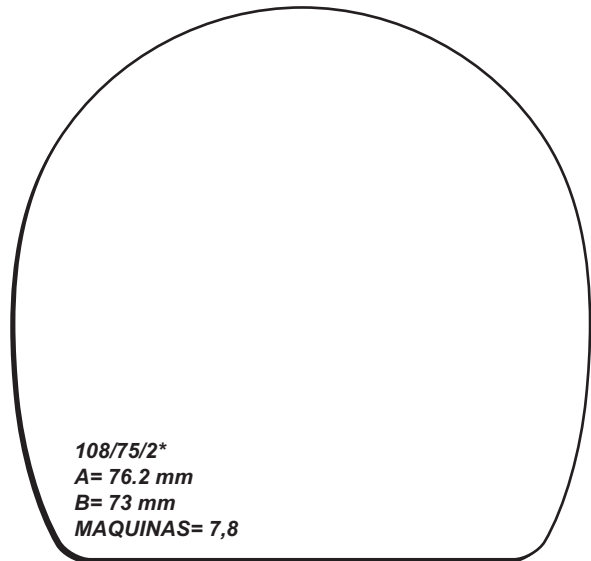
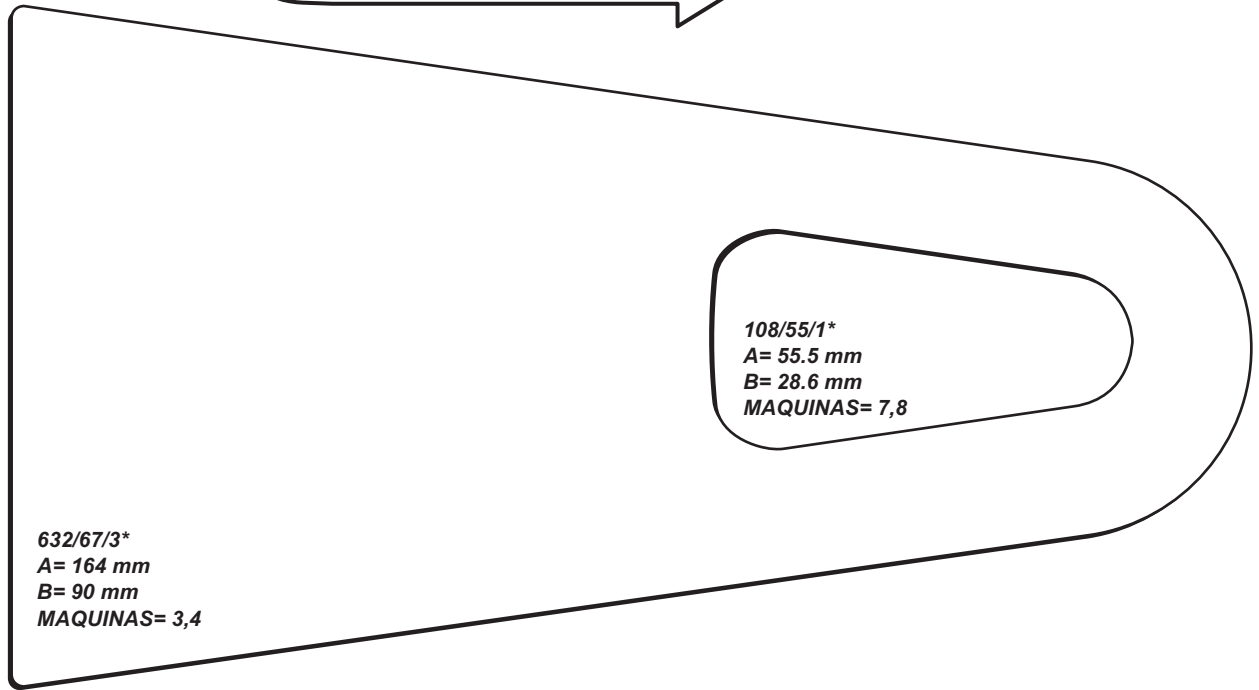
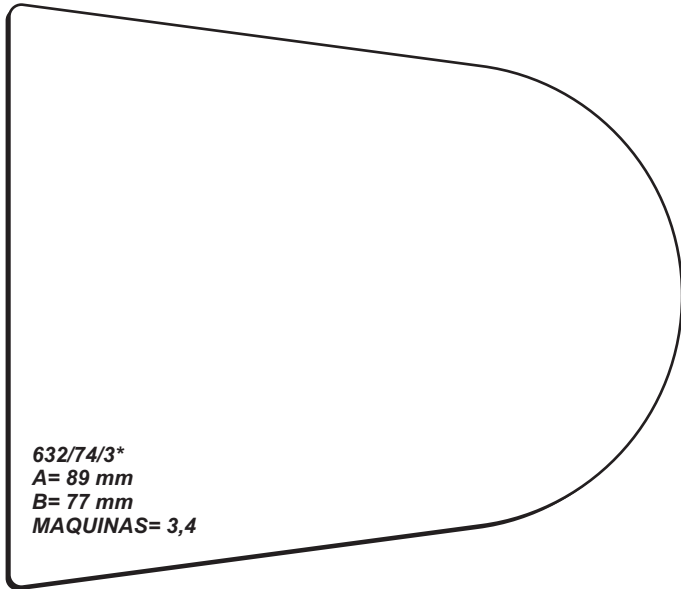



cintas y especialidades
impresas s.a. de c.v.

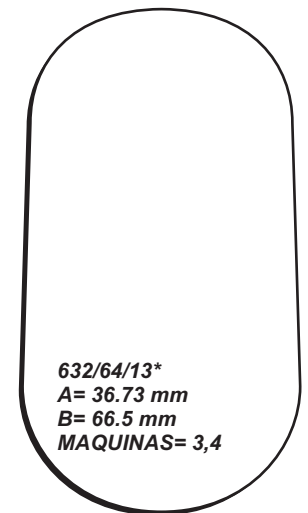
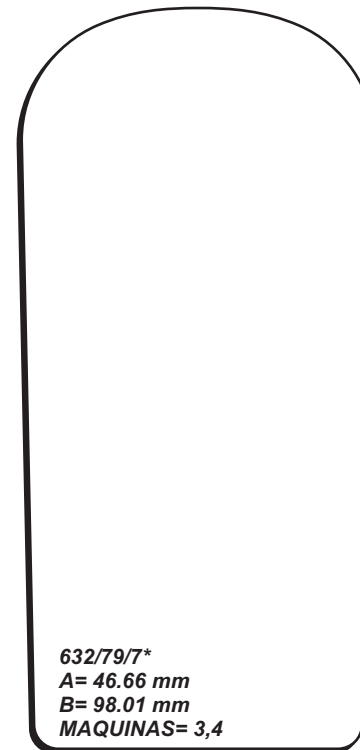
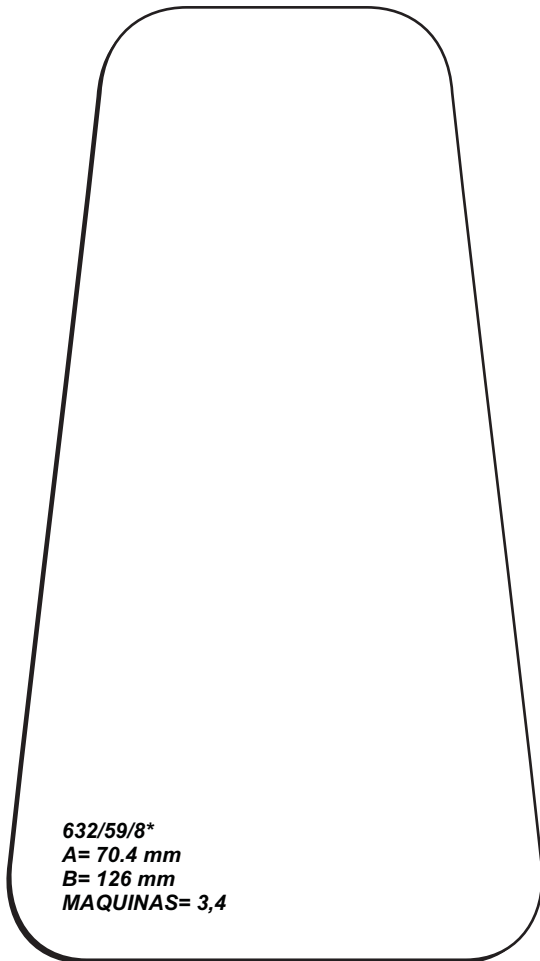



cintas y especialidades
impresas s.a. de c.v.

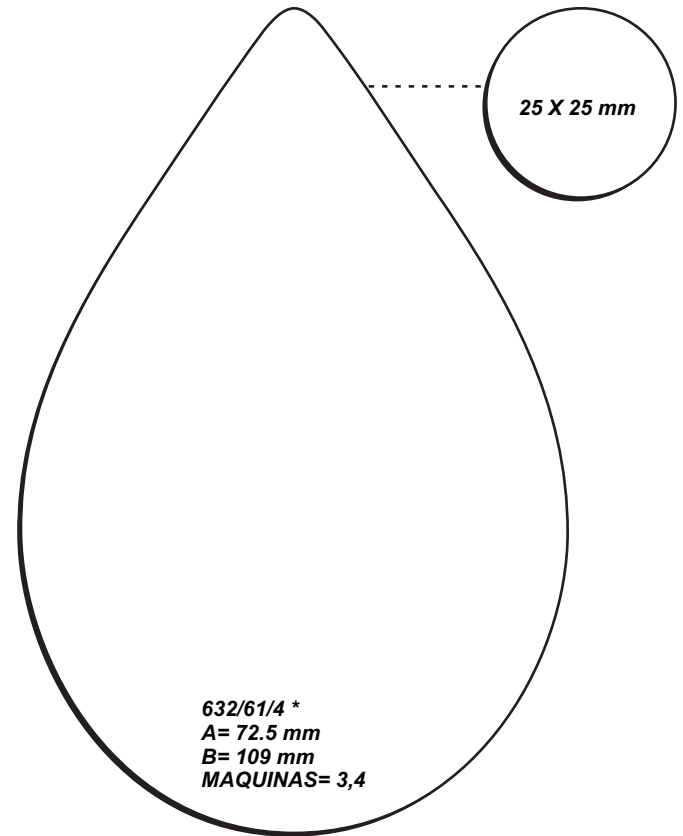
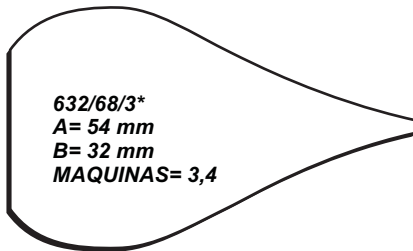
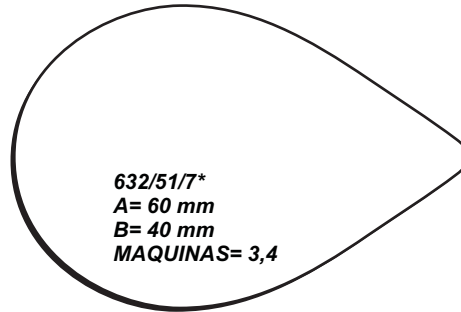
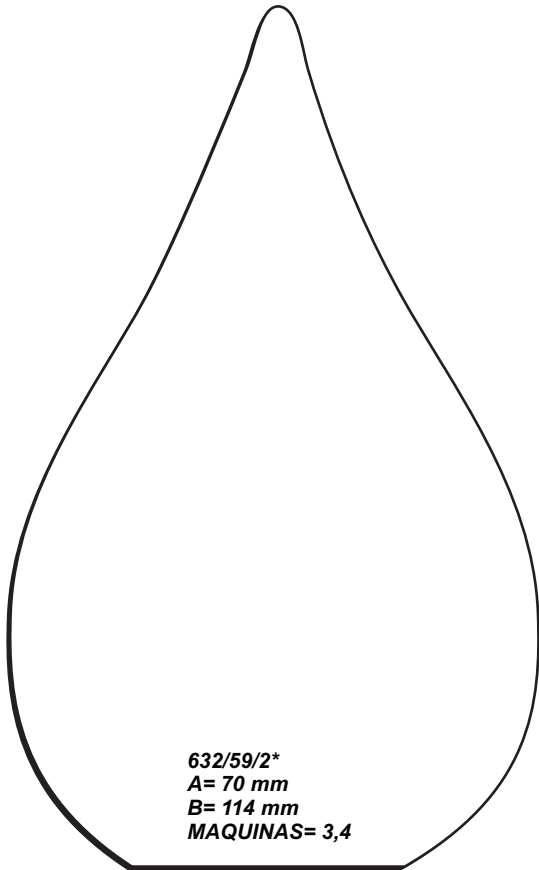

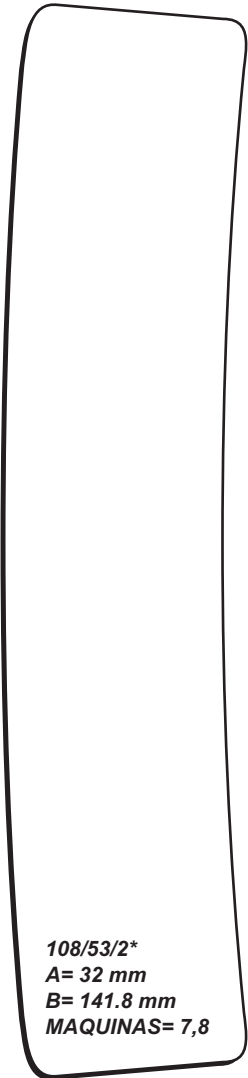

108/53/2*
A= 32 mm
B= 141.8 mm
MAQUINAS= 7,8

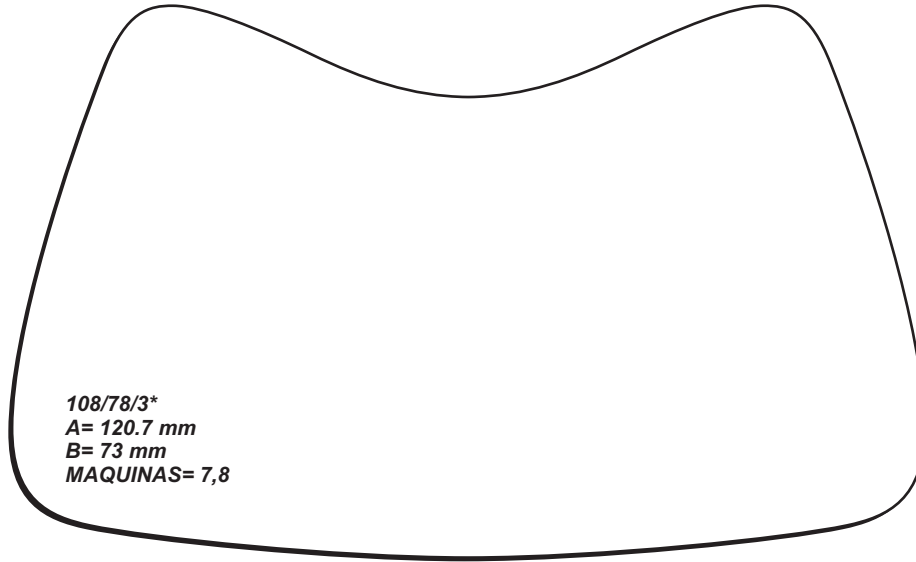

108/78/3*
A= 120.7 mm
B= 73 mm
MAQUINAS= 7,8

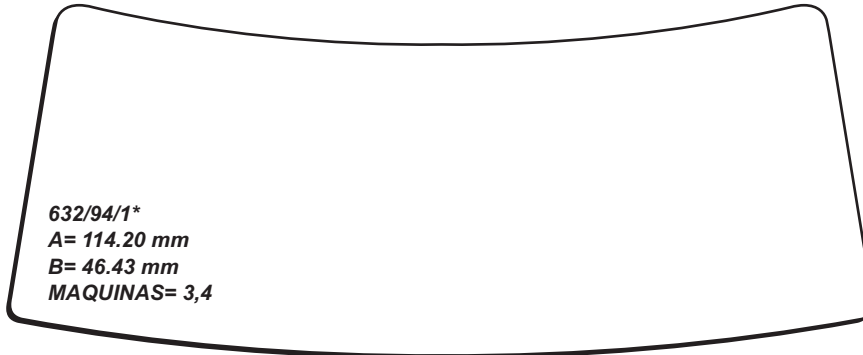

632/94/1*
A= 114.20 mm
B= 46.43 mm
MAQUINAS= 3,4



632/53/4*
A= 23.36 mm
B= 12.72 mm
MAQUINAS= 3,4

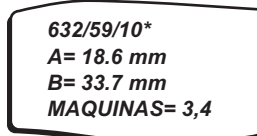

632/59/10*
A= 18.6 mm
B= 33.7 mm
MAQUINAS= 3,4

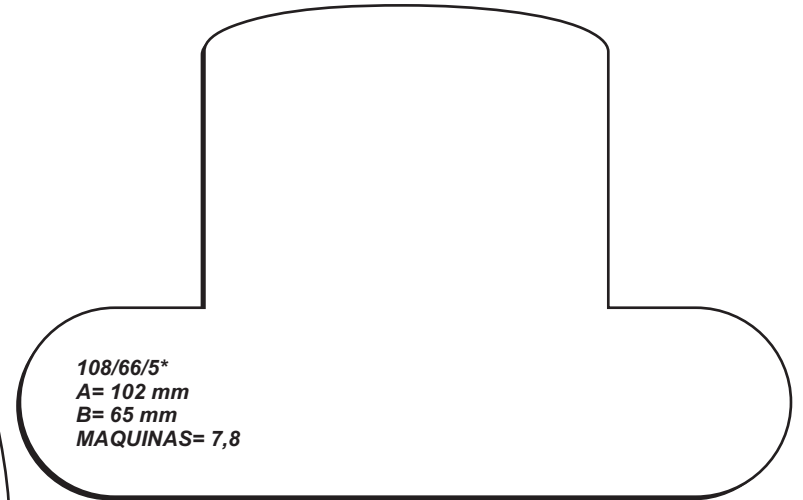

108/66/5*
A= 102 mm
B= 65 mm
MAQUINAS= 7,8

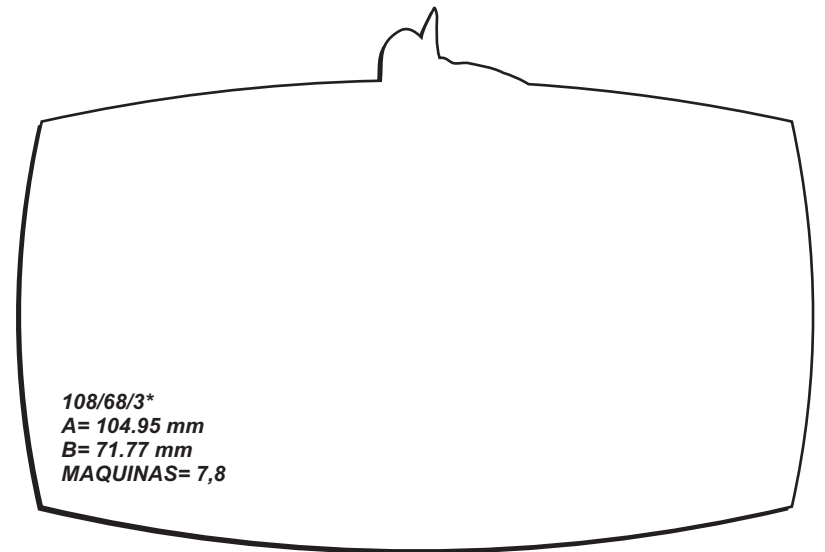

108/68/3*
A= 104.95 mm
B= 71.77 mm
MAQUINAS= 7,8



cintas y especialidades
impresas s.a. de c.v.

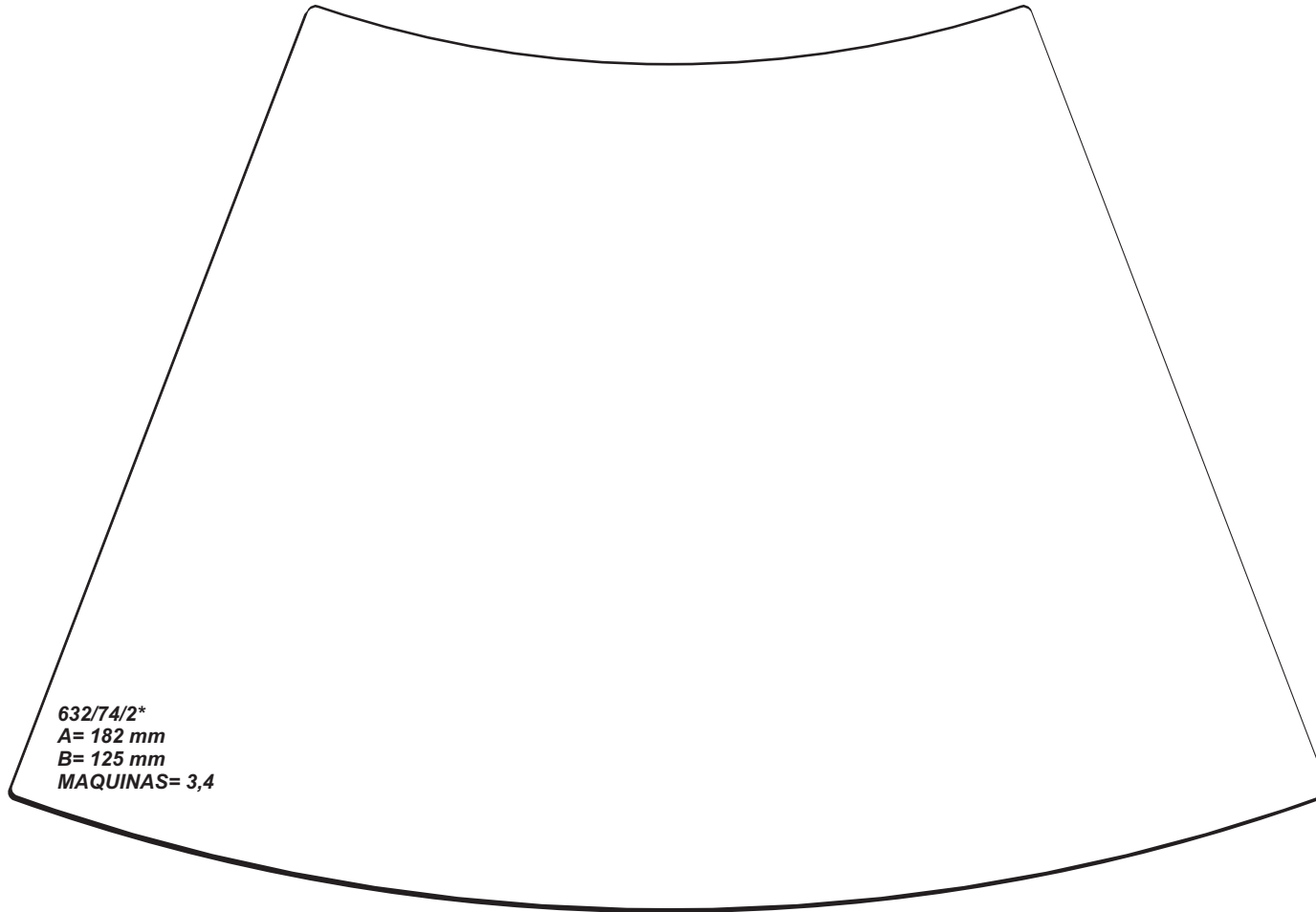

632/74/2*
A= 182 mm
B= 125 mm
MAQUINAS= 3,4



cintas y especialidades
impresas s.a. de c.v.



108/104/1*
A= 327 mm
B= 165 mm
MAQUINAS= 7,8

IMPRESO EN REDUCCION AL 75%



cintas y especialidades
impresas s.a. de c.v.

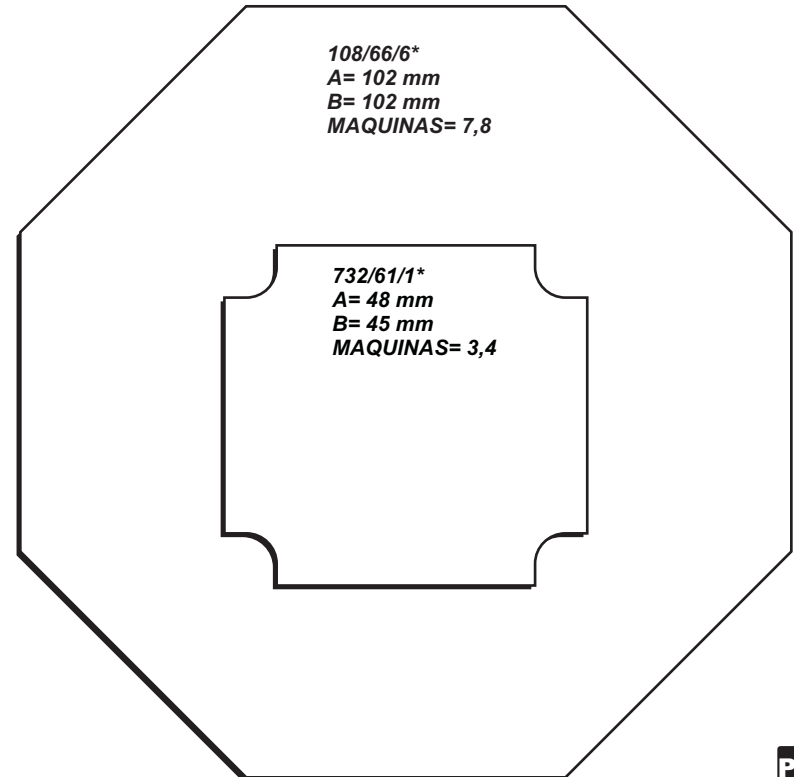
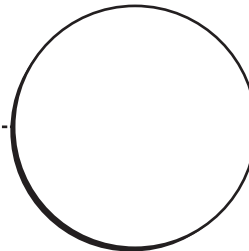
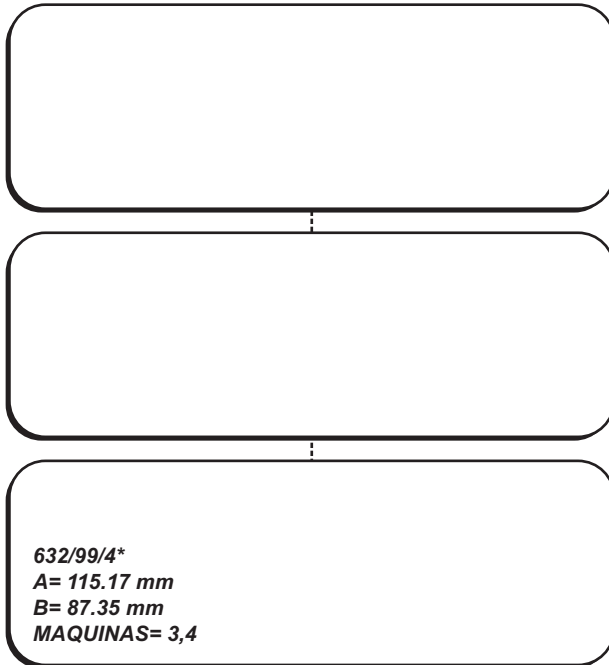
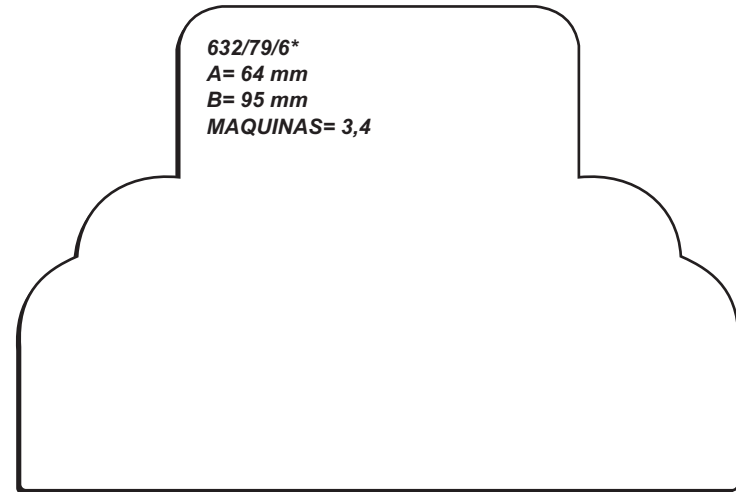
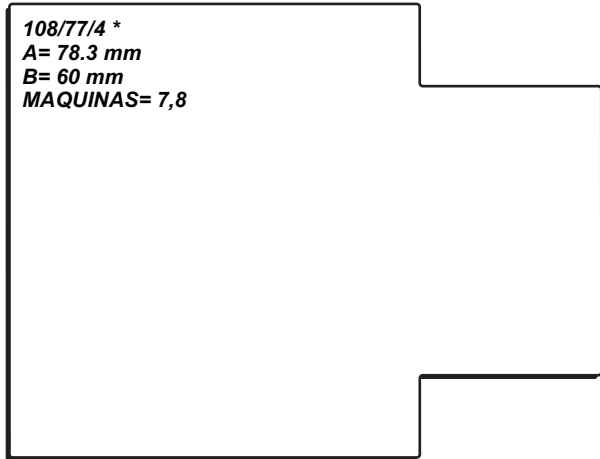



cintas y especialidades
impresas s.a. de c.v.



SUAJES ESPECIALES

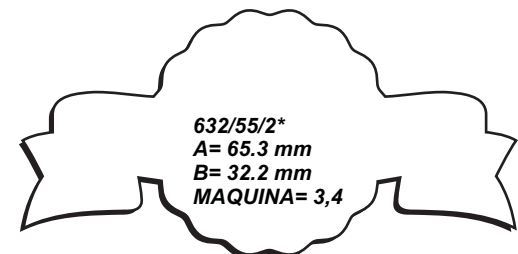
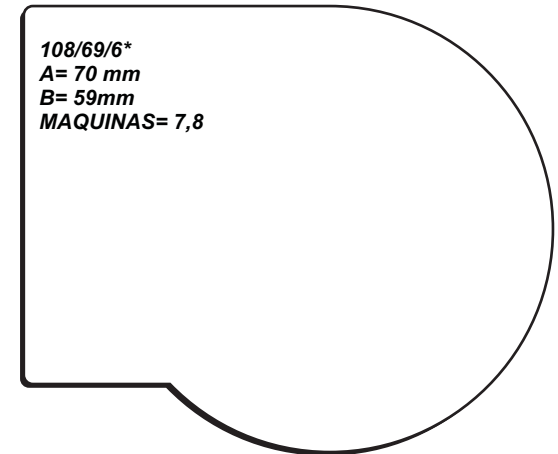
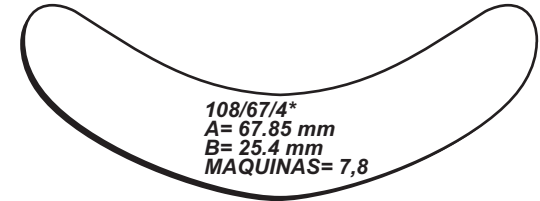
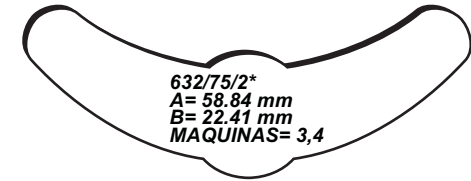
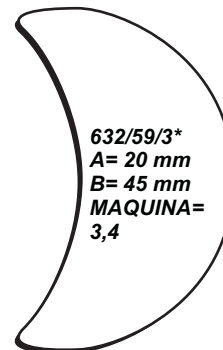
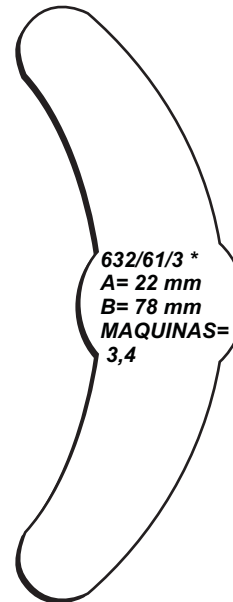
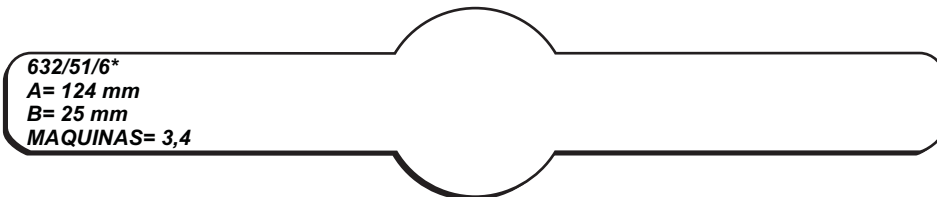
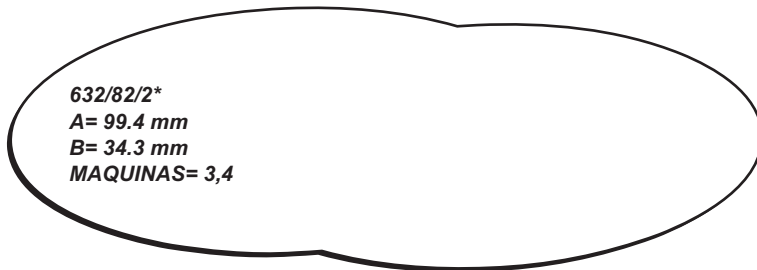
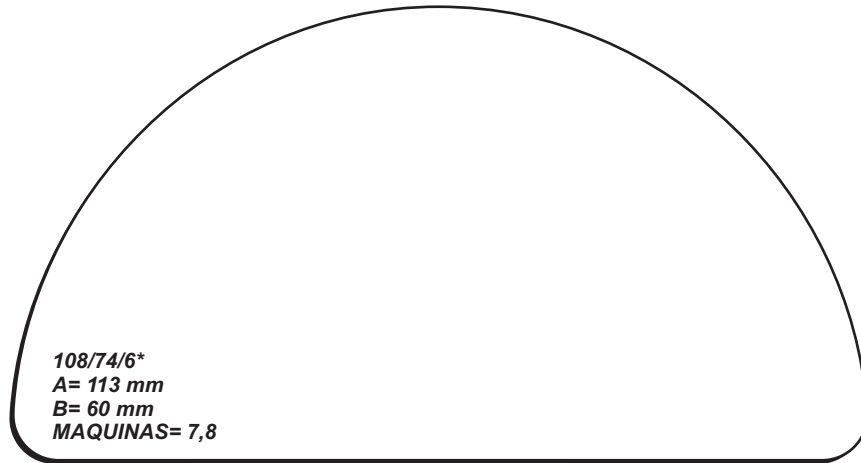



cintas y especialidades
impresas s.a. de c.v.

SUAJES ESPECIALES

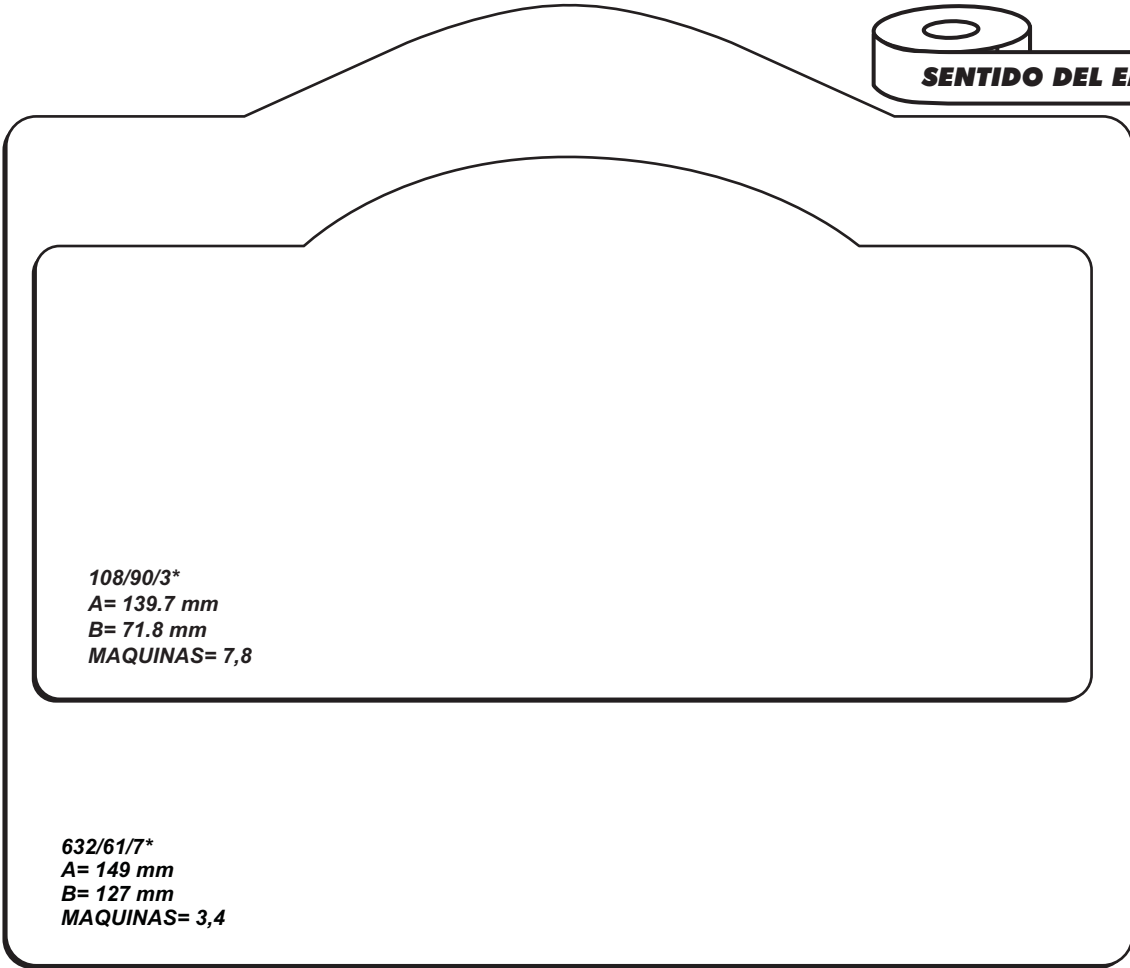

108/90/3*
A= 139.7 mm
B= 71.8 mm
MAQUINAS= 7,8

632/61/7*
A= 149 mm
B= 127 mm
MAQUINAS= 3,4

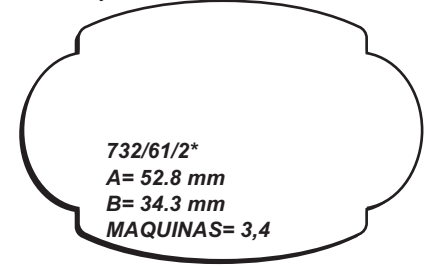

732/61/2*
A= 52.8 mm
B= 34.3 mm
MAQUINAS= 3,4

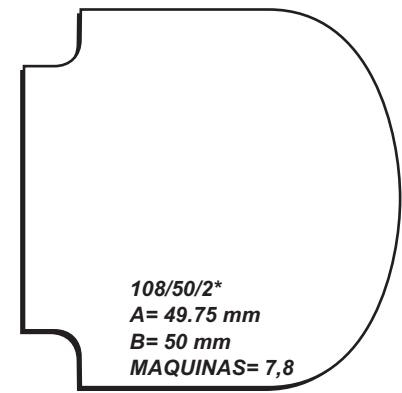

108/50/2*
A= 49.75 mm
B= 50 mm
MAQUINAS= 7,8

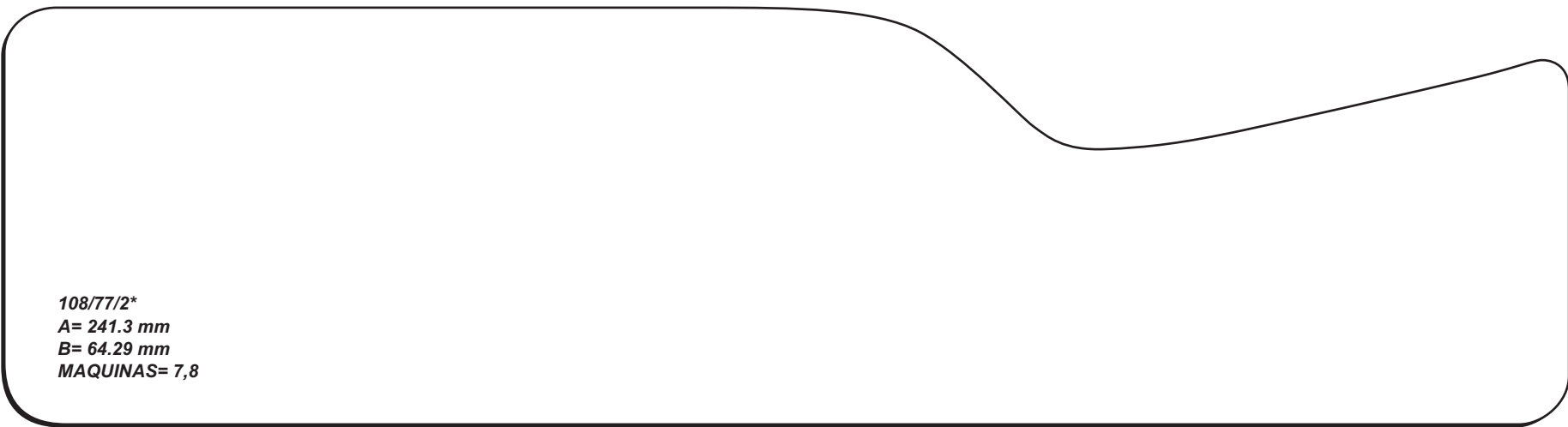

108/77/2*
A= 241.3 mm
B= 64.29 mm
MAQUINAS= 7,8



cintas y especialidades
impresas s.a. de c.v.

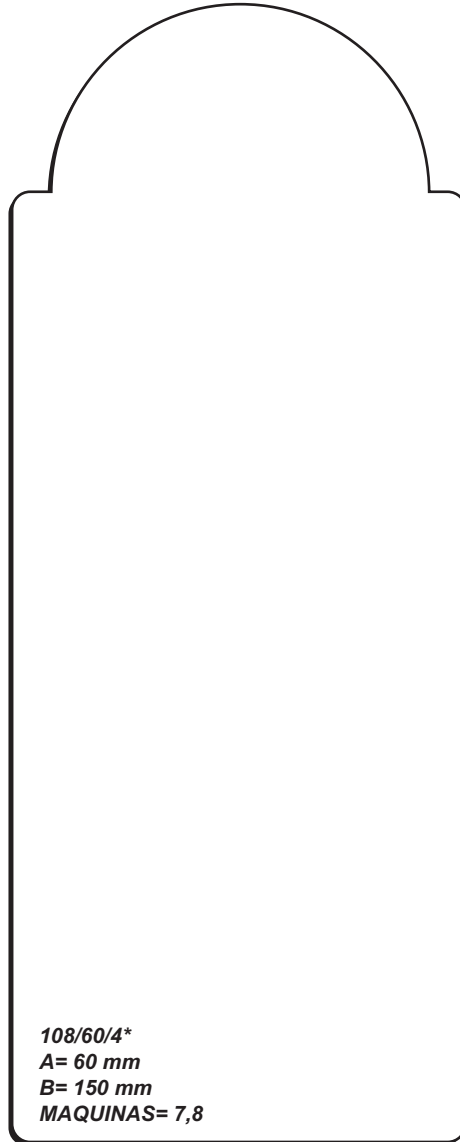
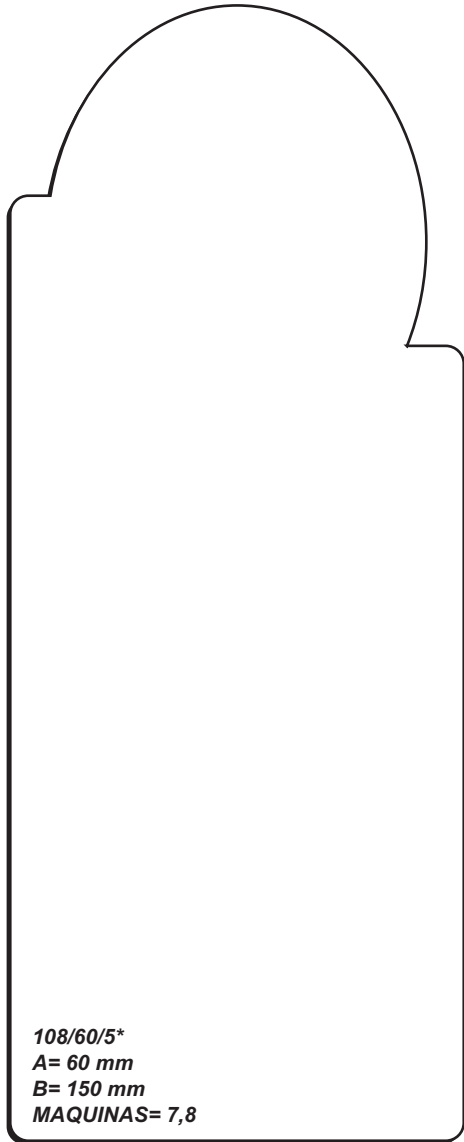



cintas y especialidades
impresas s.a. de c.v.



108/78/2*
A= 119.7 mm
B= 159.3 mm
MAQUINAS= 7,8

108/63/3*
A= 196.8 mm
B= 127 mm
MAQUINAS= 7,8



cintas y especialidades
impresas s.a. de c.v.

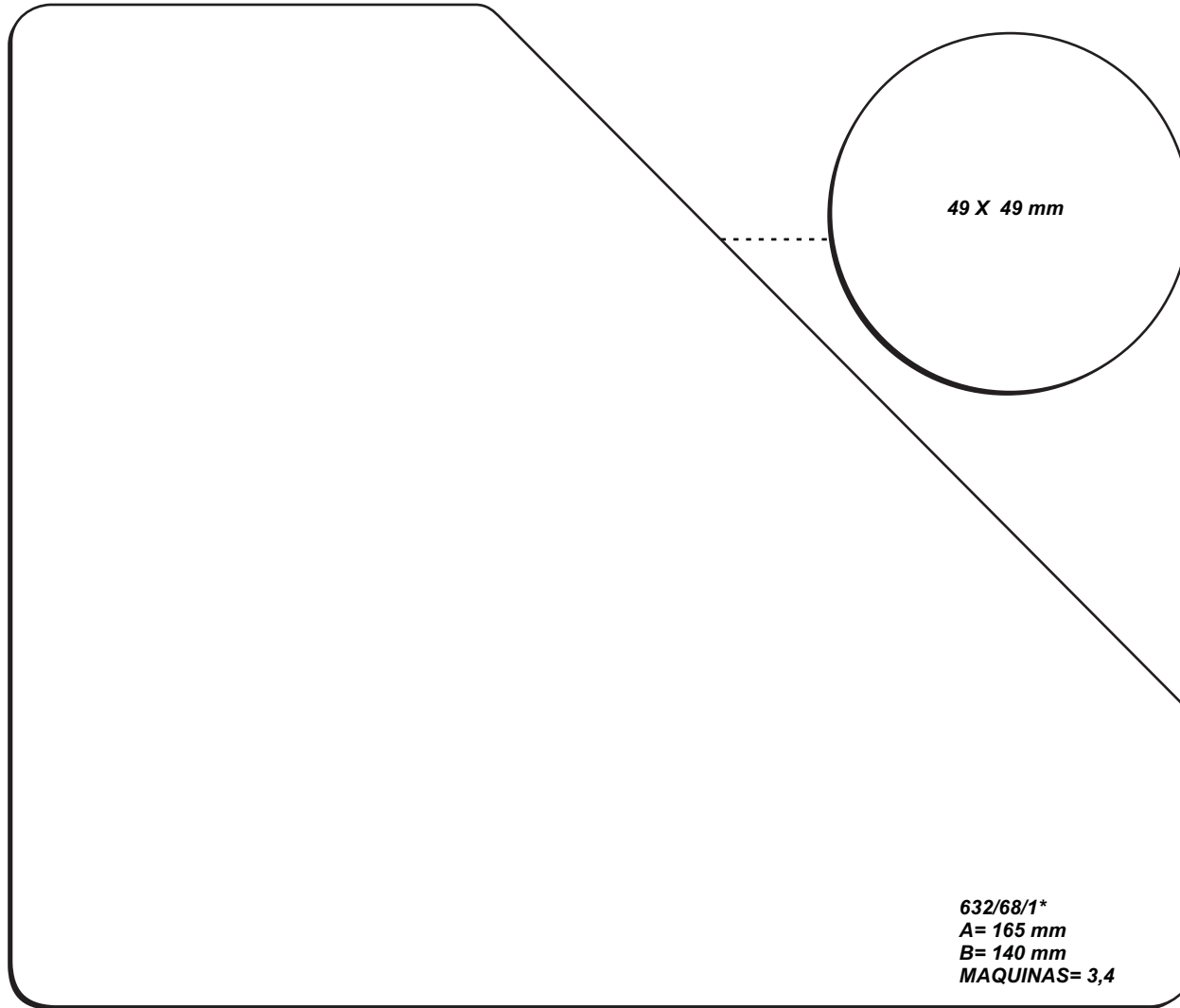



cintas y especialidades
impresas s.a. de c.v.

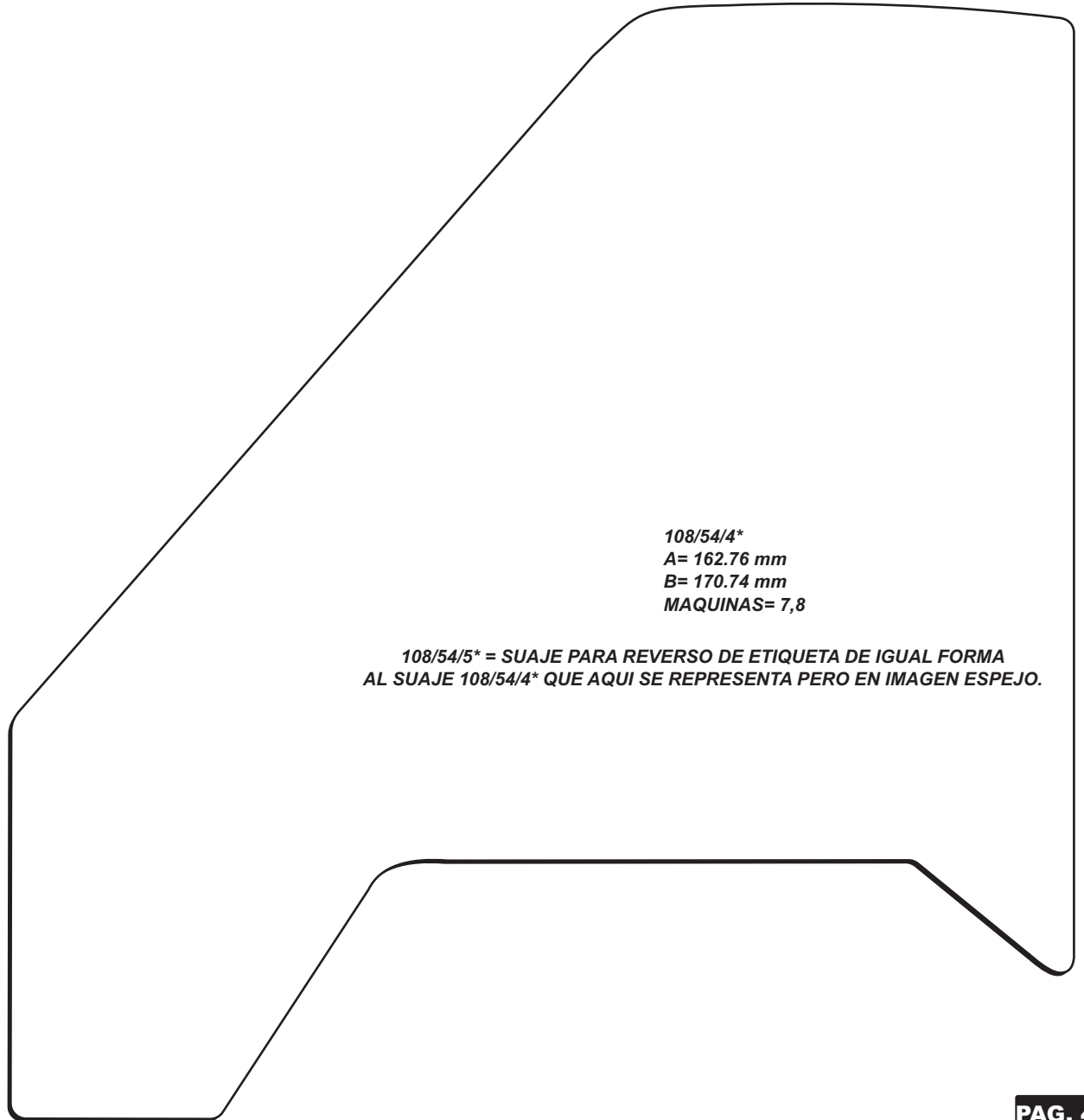
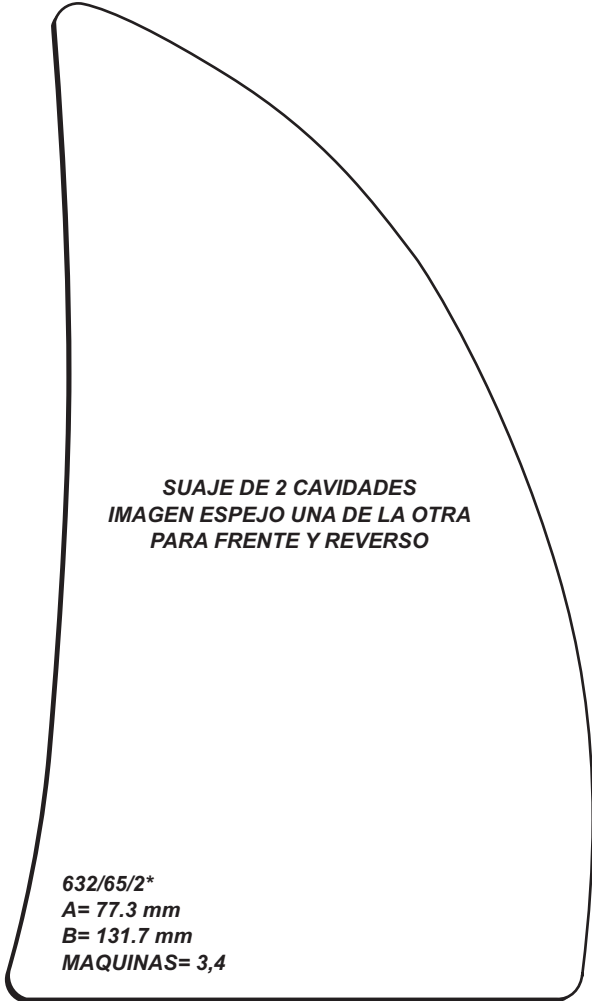



cintas y especialidades
impresas s.a. de c.v.

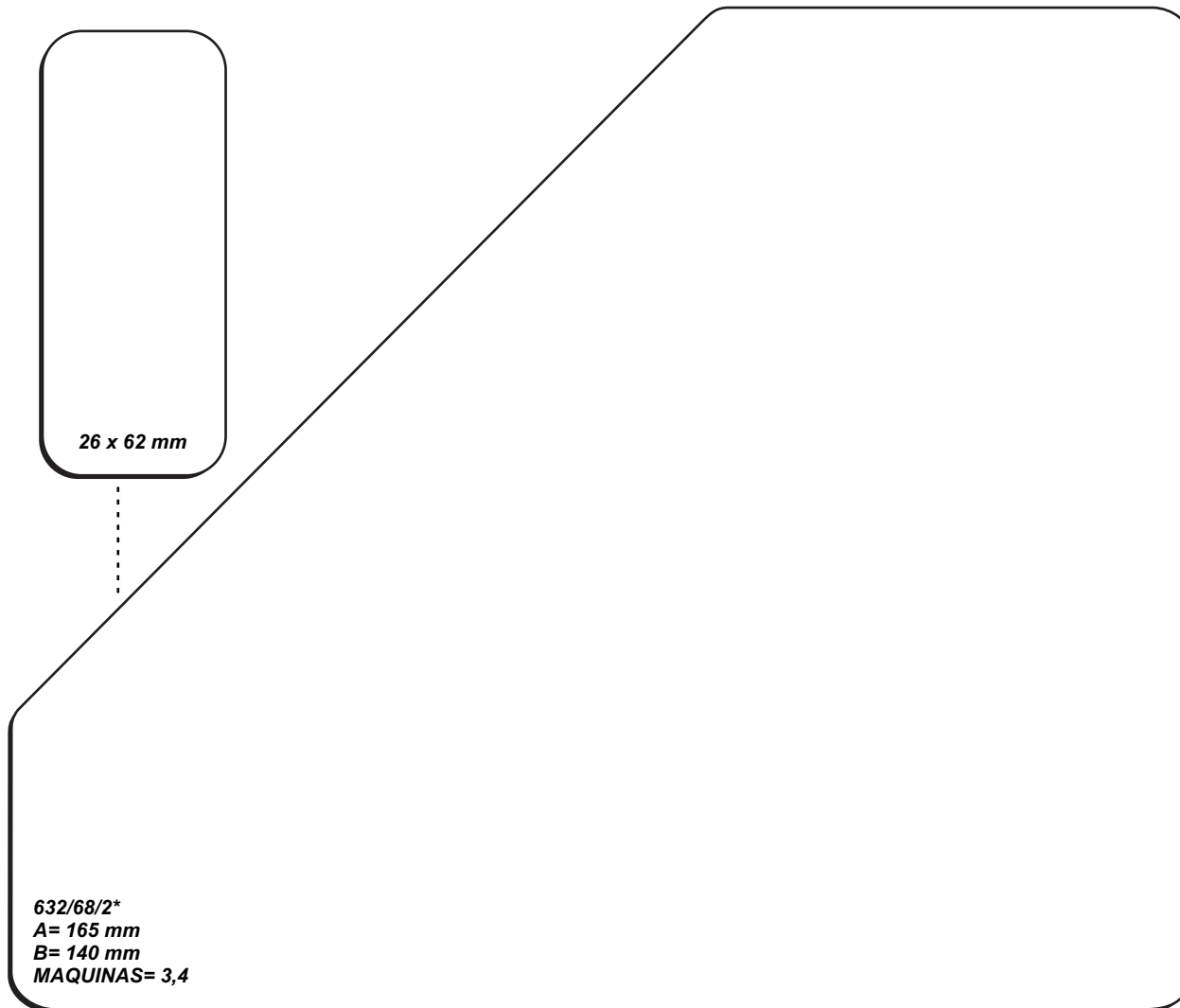



cintas y especialidades
impresas s.a. de c.v.

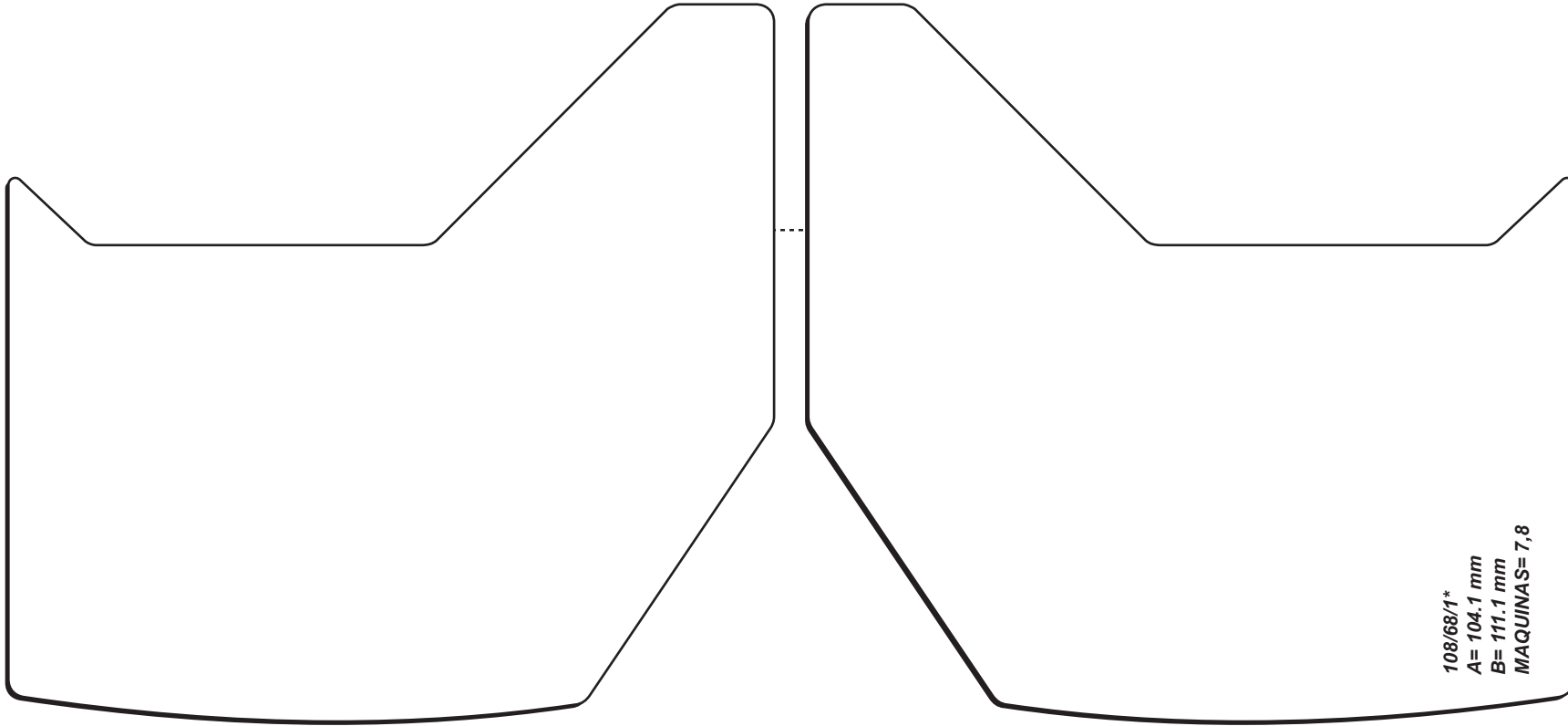

108/68/1*
A= 104.1 mm
B= 111.1 mm
MAQUINAS= 7,8



SENTIDO DEL EMBOBINADO



cintas y especialidades
impresas s.a. de c.v.

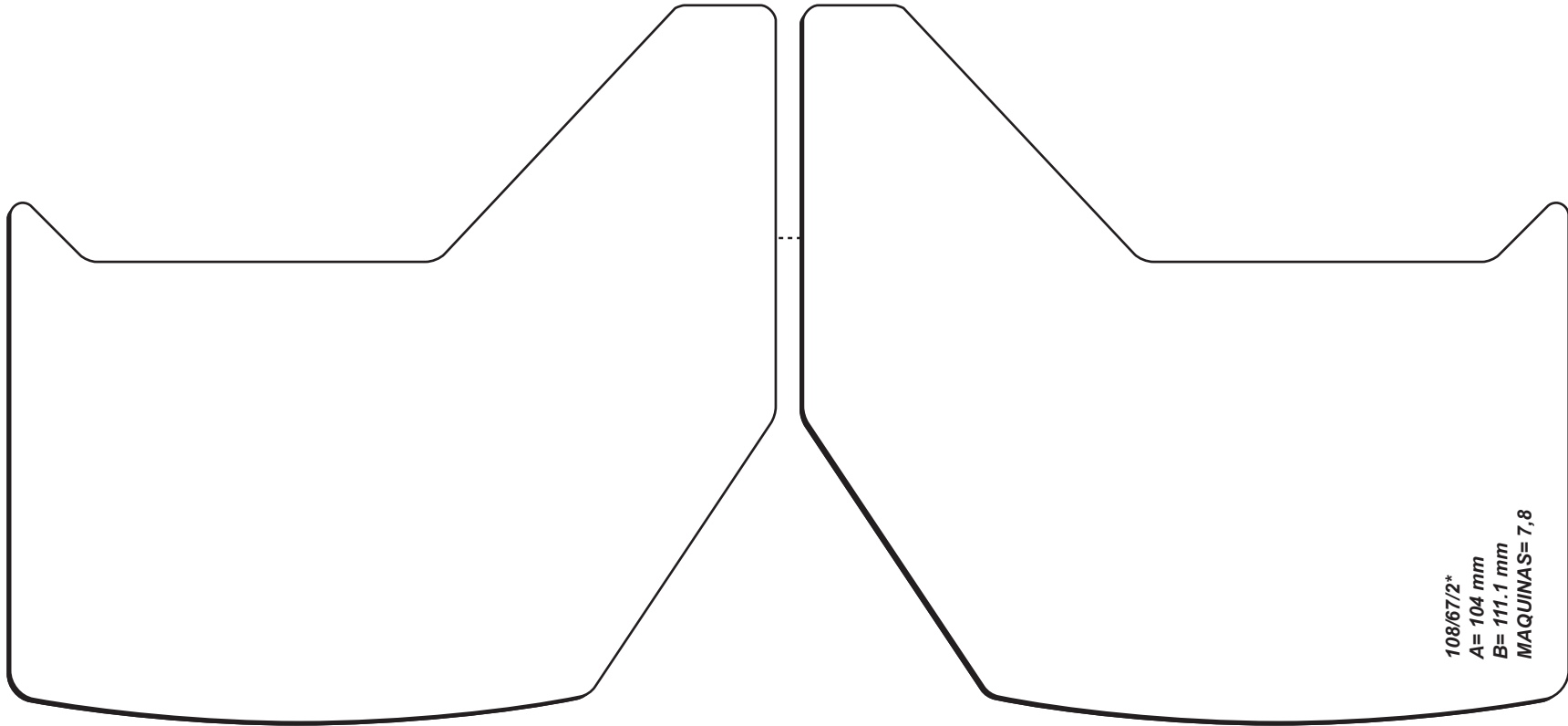

108/67/2*
A= 104 mm
B= 111.1 mm
MAQUINAS= 7,8





cintas y especialidades
impresas s.a. de c.v.



**SUAJE DE 2 CAVIDADES
IMAGEN ESPEJO UNA DE LA OTRA
PARA FRENTE Y REVERSO**

832/117/2*
A= 142.7 mm
B= 175 mm
MAQUINAS= 3,4



cintas y especialidades
impresas s.a. de c.v.



632/127/1*
A= 314.1 mm
B= 140 mm
MAQUINAS= 3,4

IMPRESO EN REDUCCION AL 75%



cintas y especialidades
impresas s.a. de c.v.



SUAJES ESPECIALES

SUAJES DE CORTE COMPLETO Y CORTE ESPECIAL

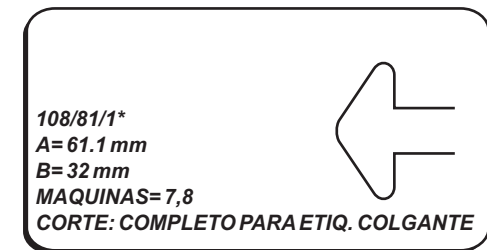
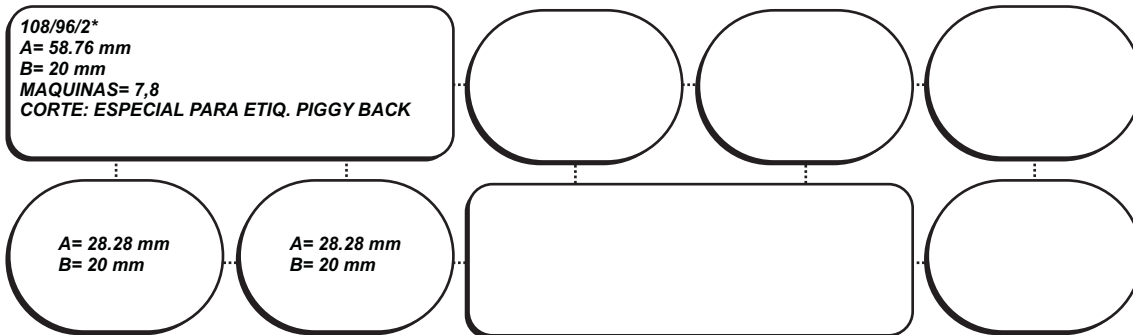
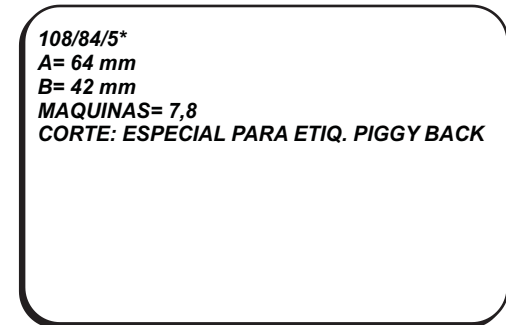
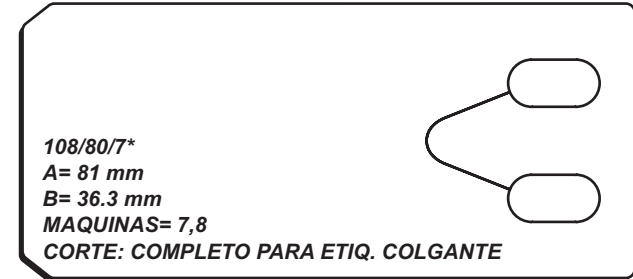
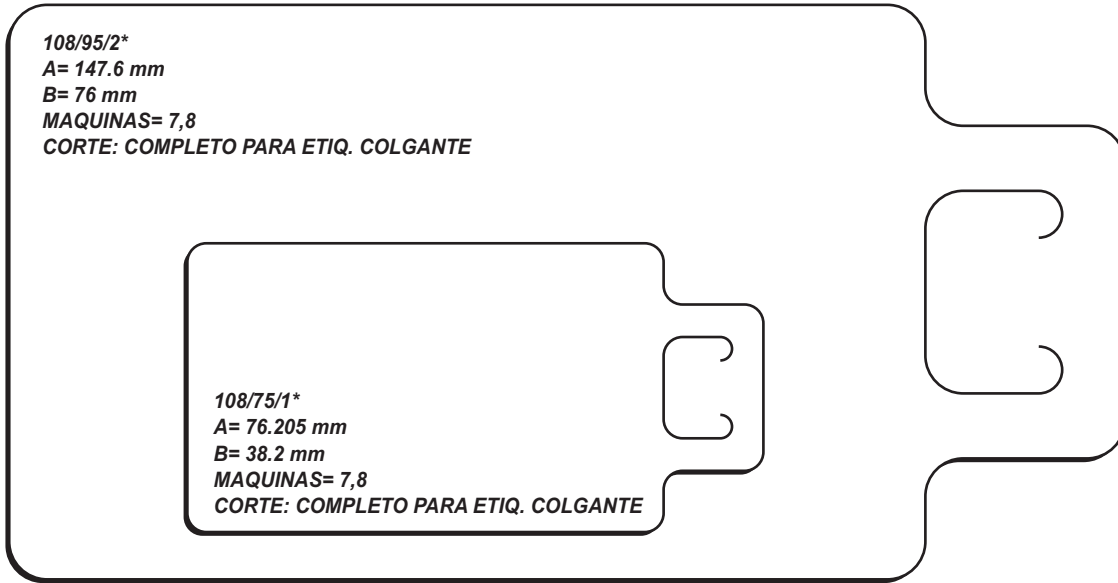



cintas y especialidades
impresas s.a. de c.v.



SUAJES ESPECIALES

SUAJES DE CORTE COMPLETO Y CORTE ESPECIAL

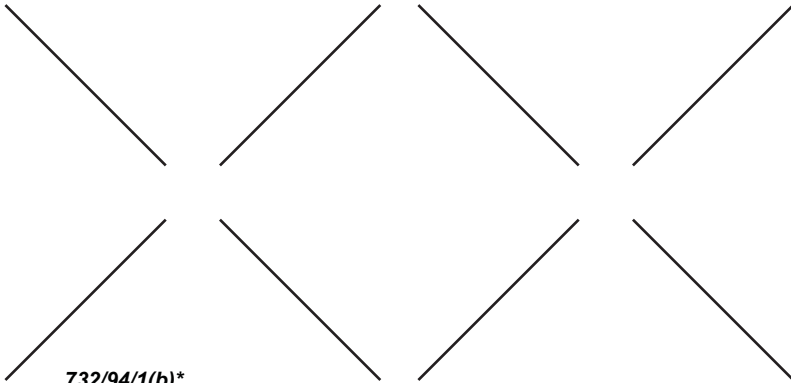

732/94/1(b)*
A= 104.23 mm
B= 49.60 mm
MAQUINAS= 3,4

632/76/2(b)*
A= 91 mm
B= 32 mm
MAQUINAS= 3,4

